

Stirrups or fibers

Autor(en): **Mortelmans, Fernand / Vandewalle, Lucie**

Objektyp: **Article**

Zeitschrift: **IABSE reports = Rapports AIPC = IVBH Berichte**

Band (Jahr): **62 (1991)**

PDF erstellt am: **23.07.2024**

Persistenter Link: <https://doi.org/10.5169/seals-47697>

Nutzungsbedingungen

Die ETH-Bibliothek ist Anbieterin der digitalisierten Zeitschriften. Sie besitzt keine Urheberrechte an den Inhalten der Zeitschriften. Die Rechte liegen in der Regel bei den Herausgebern.

Die auf der Plattform e-periodica veröffentlichten Dokumente stehen für nicht-kommerzielle Zwecke in Lehre und Forschung sowie für die private Nutzung frei zur Verfügung. Einzelne Dateien oder Ausdrucke aus diesem Angebot können zusammen mit diesen Nutzungsbedingungen und den korrekten Herkunftsbezeichnungen weitergegeben werden.

Das Veröffentlichen von Bildern in Print- und Online-Publikationen ist nur mit vorheriger Genehmigung der Rechteinhaber erlaubt. Die systematische Speicherung von Teilen des elektronischen Angebots auf anderen Servern bedarf ebenfalls des schriftlichen Einverständnisses der Rechteinhaber.

Haftungsausschluss

Alle Angaben erfolgen ohne Gewähr für Vollständigkeit oder Richtigkeit. Es wird keine Haftung übernommen für Schäden durch die Verwendung von Informationen aus diesem Online-Angebot oder durch das Fehlen von Informationen. Dies gilt auch für Inhalte Dritter, die über dieses Angebot zugänglich sind.

Stirrups or Fibers

Etriers ou fibres

Bügel oder Fasern

Fernand MORTELMANS

Professor
Cath. Univ. of Leuven
Leuven, Belgium



Fernand Mortelmans, born 1926, received his engineering degree and Ph.D. at the State University of Ghent. Currently he is carrying out research on reinforced concrete beams subjected to combined action of bending moment and shear force, cracks, steel fibers and detailing of reinforcement. He has designed several important structures in Belgium.

Lucie VANDEWALLE

Senior Assistant
Cath. Univ. of Leuven
Leuven, Belgium

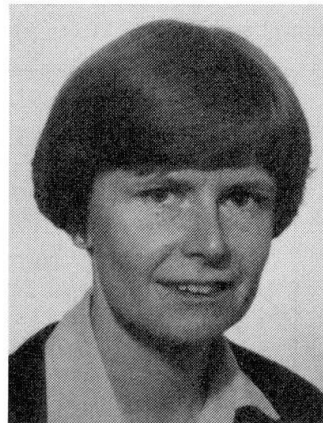

Lucie Vandewalle, born 1958, received her engineering degree and Ph.D. at the Catholic University of Leuven. Her field of research mainly concerns reinforced concrete and bond between steel and concrete.

SUMMARY

It is usual that the longitudinal reinforcement of a beam is calculated by means of the bending moment and the transverse reinforcement by means of the shear force. From extensive research carried out at the K. U. Leuven it was shown that in the compression zone of a beam a great part of the shear force is taken up. Consequently, more shear force can be taken up by the extension of the compression zone, i.e. by the provision of more longitudinal reinforcement. In this contribution an attempt is made to show that the global detailing of reinforcement may be determined by the interaction of bending moment, longitudinal and shear force.

RÉSUMÉ

Il est d'usage de déterminer l'armature longitudinale et transversale en considérant respectivement le moment fléchissant et l'effort tranchant dans une poutre. Une recherche étendue à la K. U. Leuven a démontré qu'une partie importante de l'effort tranchant est reprise dans la zone comprimée. Il est donc possible de reprendre un effort tranchant plus élevé en augmentant la zone comprimée, c.à.d. en renforçant l'armature de traction. Dans la présente communication on tente à démontrer que le dispositif complet et détaillé de l'armature peut être déterminé à partir de l'ensemble du moment fléchissant et de la force longitudinale et transversale.

ZUSAMMENFASSUNG

Es ist üblich, dass die Längsbewehrung eines Balkens aus dem Biegemoment, und die Querbewehrung aus der Querkraft berechnet wird. Aus einer umfassenden, an der K. U. Leuven durchgeführten Untersuchung hat sich ergeben, dass in der Druckzone eines Balkens ein grosser Teil der Querkraft aufgenommen wird. Es kann folglich mehr Querkraft durch Ausdehnung der Druckzone, d.h. durch Zulegen von Längsbewehrung aufgenommen werden. In diesem Beitrag wird versucht nachzuweisen, dass die gesamte Bewehrungsdetaillierung durch die Zusammenwirkung von Biegemoment, Längs- und Querkraft bestimmt werden kann.



1. INTRODUCTION

During the design of concrete structures, the determination of concrete dimensions and the detailing of reinforcement are of major concern. It is usual to calculate the longitudinal reinforcement and the transverse reinforcement independently of each other. The longitudinal reinforcement results from the bending moment and the normal force, the other reinforcement is necessary for the shear force.

This of course is a rough approach : internal forces are invented by engineers but fysically they do not exist.

2. INTERACTION BENDING MOMENT/SHEAR FORCE FOR A GIVEN CROSS SECTION

About twelve years ago, the so-called M-N-V- (bending moment (M), normal force (N) and shear force (V)) research program was started at the K.U.Leuven. From this investigation a **mathematical model** for the ultimate limit design has been developed, which permits taking into account :

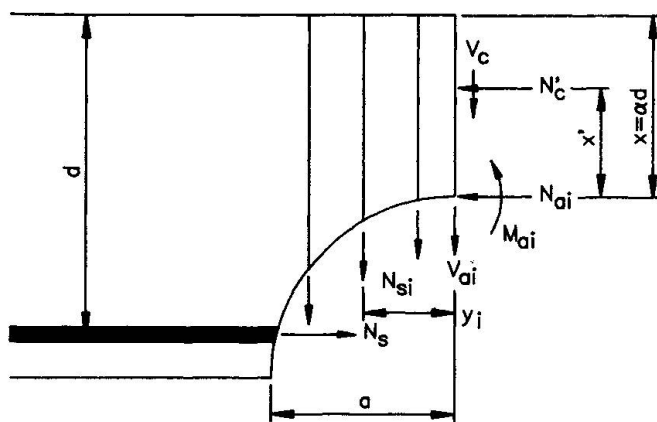

- the normal force in the compression zone (N'_c)
- the absorbable shear force in the compression zone (V_c)
- the forces in the stirrups (N_{si})
- the force in the tension reinforcement (N_s)
- the aggregate interlock (M_a, V_a, N_a)
- the shape of the crack.

The section is subjected to combined bending, compression and shear (M, N, V).

The normal force (N_c) and its situation (x') in the compressed zone can be calculated from the stress-strain diagram, proposed by CEB : [1]

$$\sigma_c = f_c \frac{\epsilon_c}{2} \left(2 - \frac{\epsilon_c}{2} \right) \quad \text{for } 0 < \epsilon_c \leq 2 \text{ ‰} \tag{1}$$

$$= f_c \quad \text{for } 2 < \epsilon_c \leq 3.5 \text{ ‰}$$

If also shear stresses act in addition to longitudinal stresses, several failure criteria can be used.

In our case (normal stress + shear stress) the simplest relation σ_I/σ_{II} is a linear function. It seems to be also a safe one.

From this relation the absorbable shear stress can be calculated

$$\tau_c = \sqrt{\frac{1}{4} \left[\left(\frac{1-K}{1+K} \right)^2 - 1 \right] \sigma_c^2 + \frac{(1-K)K}{(1+K)^2} \sigma_c + \left(\frac{K}{1+K} \right)^2} \quad \text{with } K = \frac{f_{ct}}{f_c} \tag{2),(3)}$$

This elliptic criterion is shown in figure 2.

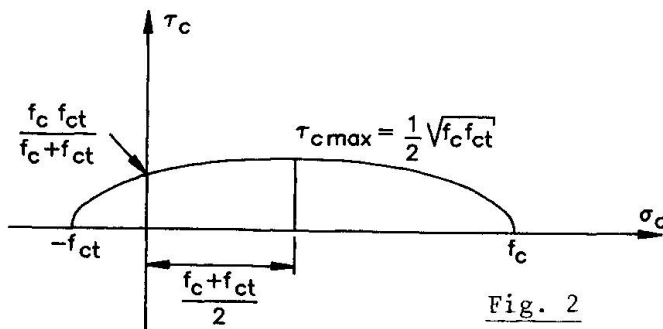

From the shear stress-diagram the shear force V_c can be calculated [2][3]. V_c as well as N_c are parameter functions of the deformation ϵ_{cu} of the concrete on the upper side.

It is then possible to draw a diagram n_c/v_c with

Fig. 2

$$n_c = \frac{N_c}{\alpha b h f_c}$$

$$v_c = \frac{V_c}{\alpha b h f_c},$$

valid for a rectangular cross section (see Fig.3).

This relation n_c/v_c has been confirmed by test results (see x in Fig. 3)[2,3,4]

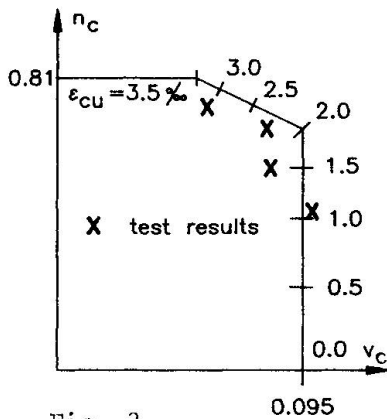

Fig. 3

Finally the horizontal projection of the crack has also been formulated by experiment for rectangular as well as for T shaped sections [6,7].

The influence of the aggregate interlock has been translated by the formulas, proposed by Prof. Walraven [5]. The shape of the crack has been determined in an experimental way [6].

The force in the reinforcement depends of course on the σ_s/ϵ_s -diagram of the steel.

The relation crack width/steel stress is based on the τ/δ relation mentioned in [8].

Expressing the equilibrium of the section, we find an interaction diagram N/V for a given longitudinal force and given dimensions of the cross-section :

$$\begin{cases} N_c + N_{ai} - N_s = N & (4) \\ V_c + V_{ai} + \sum N_{si} = V & (5) \\ N_c x' + M_{ai} + \sum N_{si} y_i + N_s (d-v) = M & (6) \end{cases}$$

Since the interaction between the different forces does not follow a linear course, the calculation can only be carried out step by step by means of a computer.

Given for example

$$\begin{aligned} b &= 300 \text{ mm} \\ d &= 650 \text{ mm} \\ f_{ck} &= 27 \text{ N/mm}^2 \\ A_s &= 4 \times 20 \text{ BE 400} \\ &\quad 3 \times 20 \text{ BE 400} \\ &\quad 2 \times 20 \text{ BE 400} \\ N_c &= 0 \end{aligned}$$

the interaction bending moment/shear force can be computed.

In Fig. 4 the interaction

$$m = \frac{M}{\alpha b h^2 f_{cd}} \quad (7)$$

$$v = \frac{V}{\alpha b h f_{cd}} \quad (8)$$

is plotted for several values of A_s (4 \times 20, 3 \times 20 and 2 \times 20) and several values of stirrup percentages ($\bar{\omega}_b = 0 - 0,1 - 0,2$).

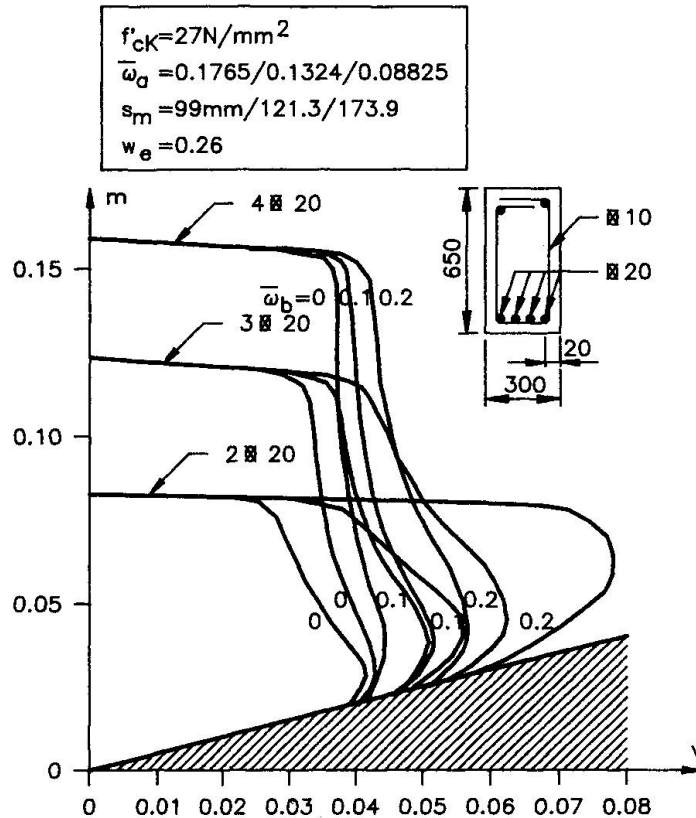

Fig. 4

3. INFLUENCE OF STIRRUPS

From the investigation as explained in 2 some important conclusions can be drawn.

1. The compression zone takes up a considerable part of the shear force.
 2. The contribution of the stirrups is rather restricted.
 3. The influence of the stirrups diminishes when the tension reinforcement increases.
 4. The aggregate interlock decreases when the tension reinforcement is reduced.
- It may be stated that when the area of the tension reinforcement increases - as a result of which the size of the compression zone expands - more shear force can be taken up by the concrete. The stirrups may then become unnecessary. So, more shear force can be taken up by increasing the tension reinforcement or by applying a (limited) prestressing.

The mathematical model is applicable both for reinforced concrete, for prestressed concrete and for partially prestressed concrete.

At the moment, an attempt is being made to incorporate the mathematical model in a calculation method, which is easy to handle in practice.

When the aggregate interlock is not taken into account - which means an additional safety - the calculation already becomes a good deal more simple.

4. RELATION BENDING MOMENT/SHEAR FORCE FOR A GIVEN LOAD

Let us consider a beam on two supports (length ℓ) with a uniformly distributed load (p). The longitudinal force is zero. The bending moment M and the shear force V at a distance x from the left support can be formulated as ($t = x/\ell$) :

$$M = \frac{p\ell^2}{2} (1 - t)t \quad (9)$$

$$V = \frac{p\ell}{2} (1 - 2t)$$

Eliminating t between M and V and introducing the notations m_p , v_p and λ

$$m_p = \frac{M}{b h^2 f_{cd}} \quad (10)$$

$$v_p = \frac{V}{b h f_{cd}} \quad (11)$$

$$\lambda = \frac{p\ell^2}{8 b h^2 f_{cd}} \quad (12)$$

we find an interaction m_p/v_p

$$m_p = \lambda \left[1 - \left(\frac{v_p}{\lambda} \right)^2 \left(\frac{\ell}{h} \right)^2 \right] \quad (13)$$

This interaction m_p/v_p due to the load p is to be secured by the interaction diagram m_o/v_o that the section is capable to bear ($m_o = \alpha m$, $\alpha_o = \alpha v$).

In the figure 5 both interactions are drawn schematically.

Full lines represent the load relation, dotted lines concern the "bearing capacity" of the chosen section for stirrup percentages $\bar{\omega} = 0 - 0,1$ and $0,2$.

For the case drawn in figure 5 it is clear that for a slender beam ($h/\ell = 0,05$ and even $h/\ell = 0,10$) no stirrups are required.

When h/ℓ increases - for example $h/\ell = 0,15$ - stirrups become necessary from the point A to the point B.

So it is clear that a lot of beams can be designed without stirrups. On the other hand less slender beams may need some stirrups near to the support. At the addition of steel fibers in the concrete mix the interaction lines m_o/v_o move to the right. This has been proved by dr.ir. L. Van de Loock [9] in his doctor's thesis.

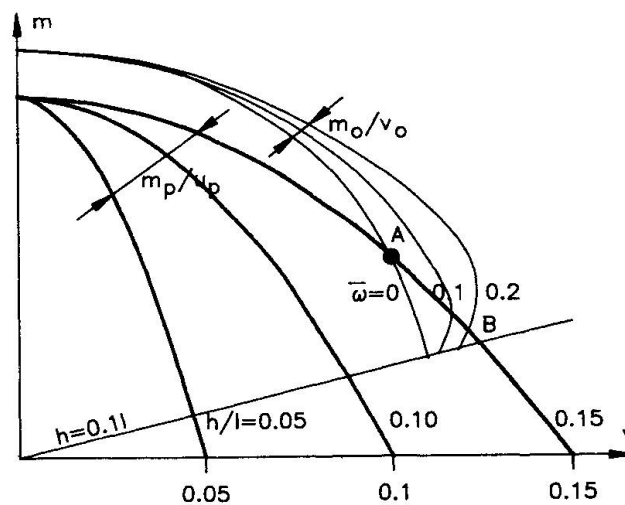

Fig. 5



5. DETAILING OF THE REINFORCEMENT

Even if no stirrups are necessary, it seems to us that it is advisable to add a limited quantity of fibers in the concrete in order to secure a minimum tensile strength and an adequate post cracking behaviour.

Of course, not all the beams can be considered for reinforcing without stirrups. We think that a scientific dosage of longitudinal reinforcement, steel fibers (15 to 20 kg/m³) and stirrups makes it possible to design more economically most of the common beams. Besides, it is known that cracks often start at the location of the stirrups.

REFERENCES

1. CEB. Modelcode 1978
2. MORTELMANS F., "Interaction diagram bending moment/shear force considering the absorbable forces in the cracked and the non cracked concrete", internal paper 20-ST-13 of 18-10-1984, Leuven.
3. MORTELMANS F., "Relatie tussen buiging en dwarskracht" (relation between bending moment and shear force), Cement nr. 10, 1985.
4. MORTELMANS F., VANDEWALLE L., "A new criterion for concrete in compression", Rilem Workshop on applications of fracture mechanics to concrete structures, Abisko (Zweden), 28-30 June 1989, (will be published by Chapman and Hall).
5. WALRAVEN J.C., "Aggregate Interlock : A theoretical and experimental analysis", University Press, Delft 1980.
6. VANDEWALLE L., CARNOY D., "Scheurpatroon van balken in gewapend beton", Afstudeerwerk K.U.Leuven, 1981.
7. HEMMATY Y., "Crack Pattern of T-section. Beams in reinforced concrete", Masters Degree 1986.
8. VOS E., REINHARDT L., "Bond resistance of deformed bars, plain bars and strands under impact loading", report 5-80-6, Delft.
9. VAN DE LOOCK L., "M-D model voor betonnen balken met rechthoekige sectie voorzien van langswapening en staalvezels" (M-V model for concrete beams with rectangular cross section with longitudinal reinforcement and steel fibers), Ph. D., K.U.Leuven 1989.