

# Strut-and-tie modelling of structural concrete

Autor(en): **Schäfer, Kurt / Schlaich, Jörg / Jennewein, Mattias**

Objektyp: **Article**

Zeitschrift: **IABSE reports = Rapports AIPC = IVBH Berichte**

Band (Jahr): **62 (1991)**

PDF erstellt am: **23.07.2024**

Persistenter Link: <https://doi.org/10.5169/seals-47645>

## **Nutzungsbedingungen**

Die ETH-Bibliothek ist Anbieterin der digitalisierten Zeitschriften. Sie besitzt keine Urheberrechte an den Inhalten der Zeitschriften. Die Rechte liegen in der Regel bei den Herausgebern.

Die auf der Plattform e-periodica veröffentlichten Dokumente stehen für nicht-kommerzielle Zwecke in Lehre und Forschung sowie für die private Nutzung frei zur Verfügung. Einzelne Dateien oder Ausdrucke aus diesem Angebot können zusammen mit diesen Nutzungsbedingungen und den korrekten Herkunftsbezeichnungen weitergegeben werden.

Das Veröffentlichen von Bildern in Print- und Online-Publikationen ist nur mit vorheriger Genehmigung der Rechteinhaber erlaubt. Die systematische Speicherung von Teilen des elektronischen Angebots auf anderen Servern bedarf ebenfalls des schriftlichen Einverständnisses der Rechteinhaber.

## **Haftungsausschluss**

Alle Angaben erfolgen ohne Gewähr für Vollständigkeit oder Richtigkeit. Es wird keine Haftung übernommen für Schäden durch die Verwendung von Informationen aus diesem Online-Angebot oder durch das Fehlen von Informationen. Dies gilt auch für Inhalte Dritter, die über dieses Angebot zugänglich sind.

## Strut-and-Tie Modelling of Structural Concrete

Analogie du treillis dans les structures en béton

Stabwerksmodelle für Konstruktionsbeton

### Kurt SCHÄFER

Prof. Dr.  
Univ. of Stuttgart  
Stuttgart, Germany

Kurt Schäfer, born 1936, worked in different positions as a design engineer and research associate in Germany and at Stanford University, California, before he was appointed Professor at Stuttgart University in 1976.

### Jörg SCHLAICH

Prof. Dr.  
Univ. of Stuttgart  
Stuttgart, Germany

Jörg Schlaich is Professor and Director of the Institut für Tragwerksentwurf und -konstruktion (Inst. for Structural Design), formerly called Institut für Massivbau (Inst. for Concrete Structures) at the University of Stuttgart and Consulting Engineer with Schlaich, Bergermann und Partner, Stuttgart.

### Mattias JENNEWAIN

Dr.-Ing.  
Univ. of Stuttgart  
Stuttgart, Germany

Mattias Jennewein, born 1948, studied at the University of Stuttgart, worked for five years in a consulting firm for ten years in the Institute for Structural Design, Univ. of Stuttgart where he worked for his doctorate on the design of structural concrete with strut-and-tie-models.

### SUMMARY

Strut-and-tie models can illustrate very well the internal flow of forces in structural concrete and thereby, provide valuable assistance to the designer who is striving for an appropriate and functional conceptual design. Moreover, such models are good enough to serve as a basis for the design and dimensioning of the modelled structure or structural detail for the cracked state. After some introductory statements this will be demonstrated by the example of a box girder, cantilevering from two supporting walls. Different arrangements of diaphragm walls and the effect of prestressing will be discussed.

### RÉSUMÉ

L'analogie du treillis permet de visualiser de façon très claire le cheminement des forces dans les structures en béton; ceci constitue une aide précieuse pour l'ingénieur lors du dimensionnement approprié d'éléments porteurs ainsi que des détails de construction. De plus, de tels modèles représentent le fondement du calcul des constructions en béton armé et précontraint à l'état fissuré. Après quelques remarques introductives, ces faits sont démontrés à l'aide d'un exemple décrivant une poutre-caisson, dont deux parois constituent les appuis. Diverses positions d'un diaphragme intérieur ainsi que l'effet de la précontrainte dans le caisson sont successivement discutées.

### ZUSAMMENFASSUNG

Mit Stabwerksmodellen kann der innere Kraftfluss sehr anschaulich dargestellt werden. Dadurch sind sie auch eine wertvolle Hilfe für den Entwurf zweckmässiger Tragwerke und Details. Sie sind ausserdem eine geeignete Grundlage für die Bemessung von Stahl- und Spannbetonkonstruktionen im gerissenen Zustand II. Dies wird im vorliegenden Beitrag am Beispiel eines auskragenden Hohlkastenträgers gezeigt. Dabei werden verschiedene Varianten von Querschotts und die Wirkung der Vorspannung diskutiert.



## 1. INTRODUCTION

Breen [4] proclaimed as a key topic of this conference "useful and transparent models, which can enhance the designer's realization of structural action" and he emphasized several times strut-and-tie models (STM) as such a tool. Schlaich, in his Introductory Report to "Modelling", integrated the strut-and-tie method into the framework of the design process of structural concrete [7]. Beginning with Ritter's truss model for beams such models were used for the visualization of forces in some specific cracked reinforced concrete elements and for proportioning their reinforcement. Thürlimann and his Zürich School developed a more general design concept using stress fields on the basis of theory of plasticity. More recently Schlaich and his co-workers proposed to generalize the strut-and-tie method for the application to all kinds of structural concrete elements or structural details and to compliment the method by a unified concept for the dimensioning of cracked structural concrete, including the node regions of struts and ties [1, 2, 3].

Such a concept is urgently needed considering the Codes of Practise, which give design rules only for elements with linear strain distribution (B-regions) but neglect all others, more complicated ones, where damage most frequently occurs. The lack of a consistent methodical approach for the design and dimensioning of such discontinuity regions (D-regions) was felt particularly bad when they were taught to the students. Considering the importance of the D-regions for the safety and endurance of structures their design cannot be left to the draftsman's skill or the engineer's good guess. Any rational approximate method is better than this state of dimensioning.

## 2. MODELLING METHODS

Basically three methods are available, which also may be combined:

- Orientation of the model, in particular the struts, at the linear theory of elasticity. Stress trajectories from FEM or stress diagrams in typical sections can be used for locating major struts and ties. A rough orientation at the elastic behaviour is necessary anyhow for compatibility and serviceability reasons.
- Analogy of the stresses with that of a fluid. This analogy - though mechanically not perfect - helps to find the "flow of forces" through the structure by the "load path method".
- Adaptation of known typical models to the specific case. This is facilitated by the fact that certain types of models repeat very frequently in different structures.

The general methods of finding and judging strut-and-tie models are published in some detail in [2, 3] and therefore will not be repeated here. Instead, an example will be presented.

## 3. SUPPORT OF A CANTILEVERING BOX GIRDER ON TWO WALLS

### 3.1 General Layout

How to carry the forces in the connection of the members shown in Fig. 1a? Normally diaphragm walls are introduced in the box girder, either two directly above the two supporting walls (Fig. 1b), or - because the inner one is difficult to construct - just one at the end of the box girder (Fig. 1c). The best solution, a diagonal wall, is not obvious in the beginning.

### 3.2 Frame Corner with Diaphragm Wall at the Box Girder's End only

The diagonal struts  $C_3$  (Fig. 2a) which balance the chord forces  $T_1$  (from the box girder's tensile flange) and  $T_2$  (from the tensile wall) with the compressive forces  $C_1$  and  $C_2$  from the respective compression chords of the frame type structure can only be transferred within the two webs. Therefore, all the chord forces which in the adjacent B-regions are well distributed over the whole widths of the flanges have to be deviated and bundled into the small width of the webs.

First of all, this requires considerable transverse reinforcements in the four chord members according to the strut models given in Figs. 2b-e. The models are all of one type, which appears very frequently in D-regions of very different structures. The internal lever arm  $z$  of the transverse forces in Figs. 2c and 2e, oriented at theory of elasticity is approximately  $0,6 b$ . In Figs. 2b and d the corresponding lever arm depends also on the length of overlap of longitudinal reinforcement. Standard lap lengths in Codes do not apply for this situation where the lapped bars are arranged at some distance from each other. A more detailed model (Fig. 2f) of this typical problem shows different transverse tie forces in different places.

Looking again at the struts  $C_1$  and  $C_2$  in plan and sections of Fig. 2 we realize that the corresponding stress fields must be squeezed through the bottleneck of the singular node 2 whose dimensions are restraint by the

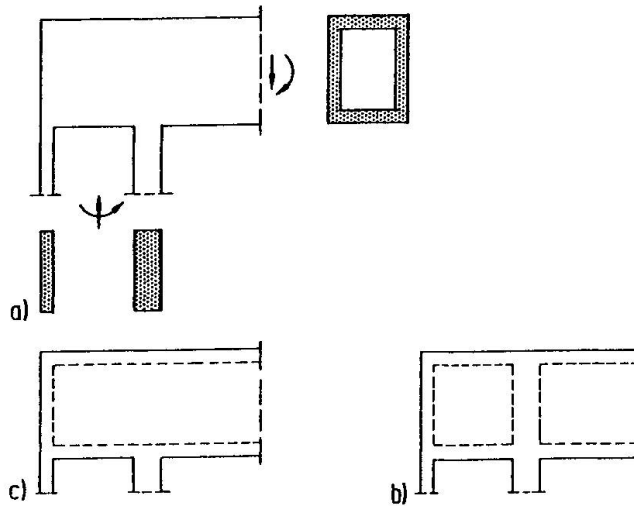

Fig. 1: a) View and cross-section of the box girder and support walls. b) Longitudinal section with interior diaphragm wall. c) Longitudinal section without interior diaphragm wall

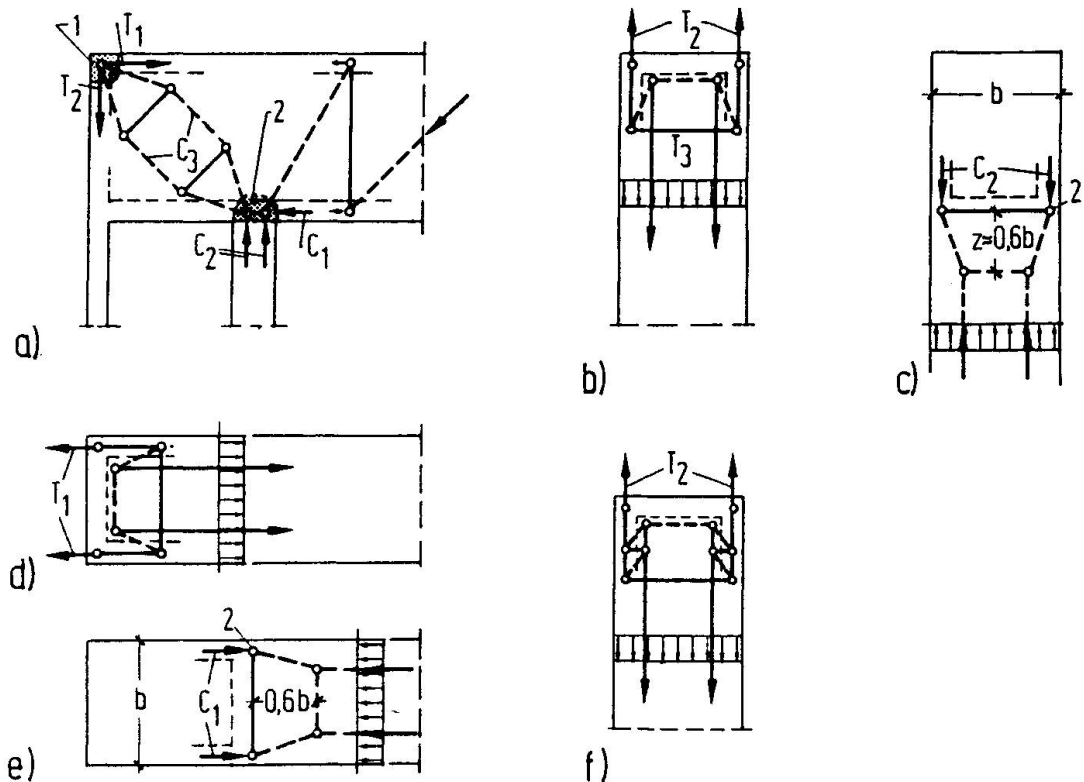

Fig. 2: Strut-and-tie models for the structure without internal diaphragm wall. a) Web; b) tensile wall; c) compression wall; d) top flange; e) bottom flange. f) Refined model for the lap problem characterized in Figs. b and d

thicknesses of the compression wall, web and bottom slab of the box girder. This node will dictate the concrete dimensions, the large width  $b$  of the boxgirder slab cannot be used as compression zone. What an unreasonable structure! Who would have recognized this, applying the usual design rules?

A similar problem may arise in node 1, where tensile bars for the total chord forces  $T_1$  resp.  $T_2$  must be arranged within the thickness of the web or at least very close to it in order to avoid large "slab moments" in



the deck and wall. Also this node will become a singular node if reinforcing bars were bent sharply around the corner as shown in Fig. 2a. Consequently, the diagonal strut force  $C_3$  in the web will spread out between nodes 1 and 2, thereby creating transverse tensile forces as indicated in Fig. 2a. Therefore it is much better to bend the chord reinforcement using a mandrel which is adapted to the dimensions of the frame corner (Fig. 3).

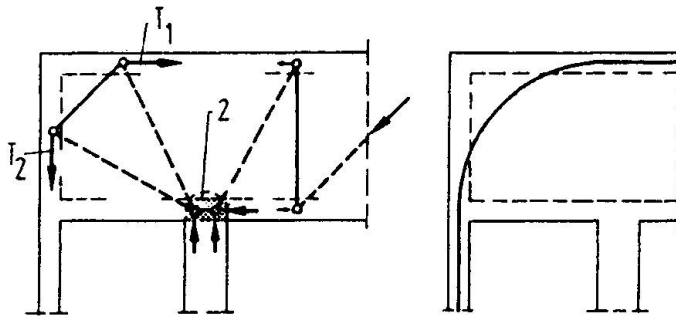

Fig. 3: Model and corresponding chord reinforcement with a well adapted mandrel diameter

By the way, omitting the lower diaphragm plate between the two walls would do no additional harm to the (poor) structural solution. Either none or two orthogonal diaphragms are needed, as will be shown hereafter.

### 3.3 Frame Corner with Two Diaphragm Walls

The necessary transverse reinforcement in the boxgirder plates and the supporting walls is the same as before; but the singular nodes are avoided since the chord forces  $T_1$ ,  $T_2$ ,  $C_1$ ,  $C_2$  now enter the web reasonably well distributed over the whole length of the diaphragms (Fig. 4a). In other words: Each chord plate is no longer supported on two points only but rather along two lines (Fig. 4b). As a consequence the load bearing capacity of the frame corner is essentially increased by the additional diaphragm wall.

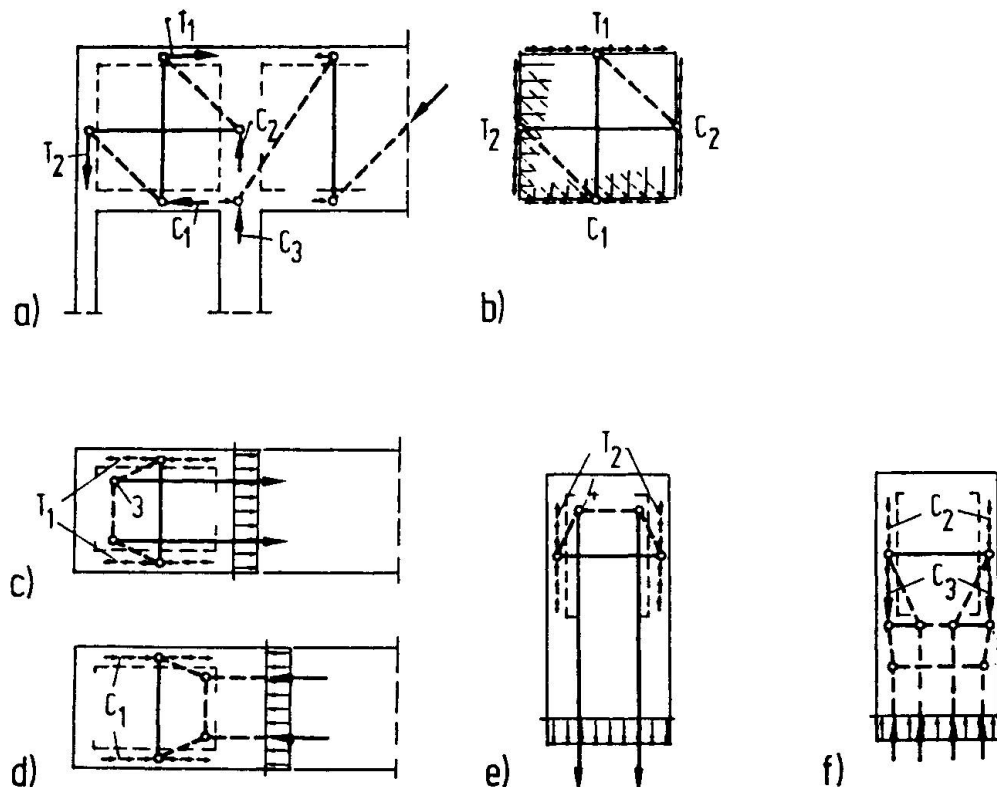

Fig. 4: Strut-and-tie models for the structure with internal diaphragm wall. a) Basic model for the web; b) refined model for the web with smeared forces. c) Top flange. d) Bottom flange. e) Tensile wall. f) Compression wall

### 3.4 Frame Corner with Diagonal Diaphragms

The best structural solution for the discussed problem is the diagonal diaphragm which follows the load path  $T_2$  in Fig. 5a. This model avoids not only the singular nodes but also the transverse reinforcements in the flanges and walls. Only the spreading out of the support forces  $C_3$ , resulting from the shear forces of the webs, require some transverse reinforcement  $T_3$  near the top of the compression wall (Fig. 5b).

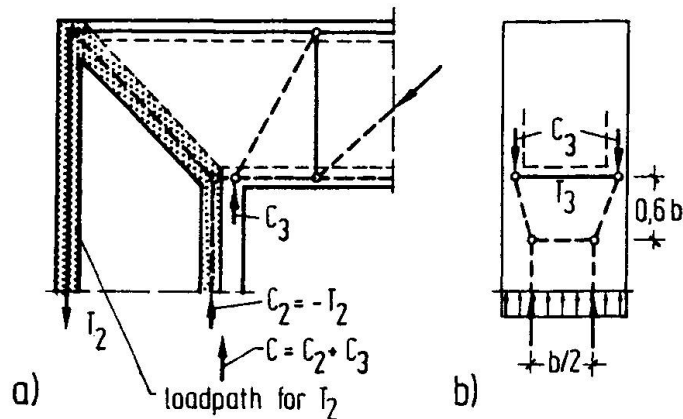

Fig. 5: a) Diagonal diaphragm following the load path for  $T_2$  of the strut-and-tie model. b) Model for the compression wall.

We can conclude from this example that strut-and-tie models are not only suitable for dimensioning but are also very helpful for the conceptual design of good structural solutions.

### 3.5 The same Structure with Prestress

Let's prestress now the top plate and tension wall of the structure without inner diaphragm wall (see Fig. 3.2) with prestressing forces  $P_1 = T_1$ ,  $P_2 = T_2$  just large enough to balance the concrete tensile forces  $T_1$ ,  $T_2$  due to dead load (Fig. 6a). At first sight one could think that thereby also the problem of transverse forces in the frame corner is cancelled, at least in the prestressed members. But it isn't at all! The model with prestress applied as external forces [4, 5, 6] discloses that the load paths of the compression forces  $C_1$ ,  $C_2$  have to squeeze as before (see section 3.2) through node 2 into webs in order to arrive at their "supports" provided by the anchor forces  $P_1$ ,  $P_2$  of the tendons. In order to avoid further detours of the load paths (see Fig. 2b and d), the tendons in the corner should be arranged within the web, either similar to Fig.3 or Fig.6b, thus balancing the compression strut in the web directly.

If the load is increased after prestressing, e.g. due to live loads or a safety factor for ultimate conditions, the tendons react like non-prestressed reinforcement with additional tendon forces  $\Delta T_1$ ,  $\Delta T_2$ . These are anchored by bond according to the model shown in Fig. 6c.

In the structure with inner diaphragm wall (acc. to Fig.4) the tendons may be distributed over the whole width  $b$  of the structure and anchored near the edge, if transverse forces are carried according to the models given in Fig.4c and e. However, the position of the model nodes 3, 4, which in Fig.4c and e represent the centroid of bond forces, have to be reconsidered for the prestressing tendons (see Fig. 6c). The prestress force  $P$  is always applied at the tendon anchor. Only that part of the tendon force  $\Delta T$  which exceeds the initial prestress force  $P$  is anchored by bond, and these bond stresses may develop at a considerable distance from the anchor.

Separating the prestressing loads from the additional tendon forces after prestressing as suggested by Breen, Bruggeling and Jennewein [4, 5, 6] is reasonable also for the application of strut-and-tie models to prestressed D-regions and leads to a clear understanding of structural behaviour.

## 4. OUTLOOK

Finding an adequate strut-and-tie model is not always as simple as in the examples shown above. It implies to have learned and practised the method for some time, like any other engineering skill or method of analysis. To develop an individual model still takes considerable time. But Rückert's contribution shows that in the future the computer can assist the design engineer also in this work [8]. And with an increasing number of published examples it will be easier to find a model which only has to be adapted to one's specific problem.

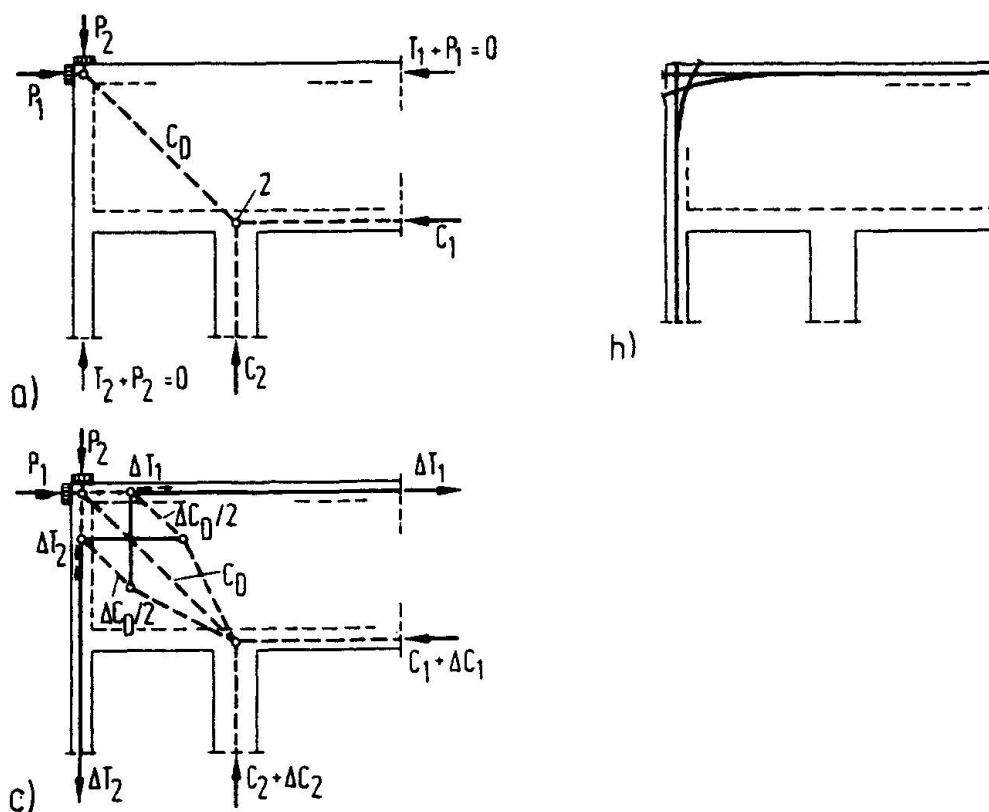

Fig. 6: Prestressed structure without internal diaphragm wall a) Top slab and tension wall prestressed under dead load to give zero concrete stresses. Model showing the load paths. b) Practical reinforcement layout c) Strut-and-tie model for increased loads, prestress as before.

At the moment standard models and procedures for dimensioning certain types of D-regions are being prepared by the authors. These include frame corners, beam-column connections, corbels and beams with openings.

In the future emphasis should be shifted from modelling techniques to a consistent design of node regions. Necessary anchorage lengths of reinforcement and permissible concrete stresses depend considerably on the type and geometry of nodes. Though the node problem is not specific for the strut-and-tie method but rather a problem of structural concrete, the authors' experience shows that strut-and-tie models help to understand and explain also the nodes' intrinsic behaviour.

## REFERENCES

1. SCHLAICH J., WEISCHEDE D., Ein praktisches Verfahren zum methodischen Bemessen und Konstruieren im Stahlbetonbau. Bulletin d'Information No. 150. CEB, Paris, March 1982
2. SCHLAICH J., SCHÄFER K., JENNEWEIN M., Toward a consistent design of structural concrete. PCI Journal vol. 32 no. 3 May/June 1987
3. SCHLAICH J., SCHÄFER K., Konstruieren im Stahlbetonbau. Betonkalender 1989. Ernst und Sohn
4. BREEN J., Why structural concrete? Introductory report. IABSE Coll. "Structural Concrete" Stuttgart 1991
5. BRUGGELING A.S.G., An engineering model of structural concrete. Introductory report IABSE Colloquium "Structural Concrete" Stuttgart 1991
6. JENNEWEIN M., Some remarks on the analytical treatment of prestressing. IABSE Coll. "Structural Concrete" Stuttgart 1991
7. SCHLAICH J., Modelling. Invited lecture. IABSE Colloquium "Structural Concrete" Stuttgart 1991
8. RÜCKERT K., Design and analysis with strut-and-tie models. - Computer aided methods. IABSE Colloquium "Structural Concrete" Stuttgart 1991