

Computer-aided automatic construction of strut-and-tie models

Autor(en): **Harisis, Argiris / Fardis, Michael N.**

Objektyp: **Article**

Zeitschrift: **IABSE reports = Rapports AIPC = IVBH Berichte**

Band (Jahr): **62 (1991)**

PDF erstellt am: **23.07.2024**

Persistenter Link: <https://doi.org/10.5169/seals-47664>

Nutzungsbedingungen

Die ETH-Bibliothek ist Anbieterin der digitalisierten Zeitschriften. Sie besitzt keine Urheberrechte an den Inhalten der Zeitschriften. Die Rechte liegen in der Regel bei den Herausgebern.

Die auf der Plattform e-periodica veröffentlichten Dokumente stehen für nicht-kommerzielle Zwecke in Lehre und Forschung sowie für die private Nutzung frei zur Verfügung. Einzelne Dateien oder Ausdrucke aus diesem Angebot können zusammen mit diesen Nutzungsbedingungen und den korrekten Herkunftsbezeichnungen weitergegeben werden.

Das Veröffentlichen von Bildern in Print- und Online-Publikationen ist nur mit vorheriger Genehmigung der Rechteinhaber erlaubt. Die systematische Speicherung von Teilen des elektronischen Angebots auf anderen Servern bedarf ebenfalls des schriftlichen Einverständnisses der Rechteinhaber.

Haftungsausschluss

Alle Angaben erfolgen ohne Gewähr für Vollständigkeit oder Richtigkeit. Es wird keine Haftung übernommen für Schäden durch die Verwendung von Informationen aus diesem Online-Angebot oder durch das Fehlen von Informationen. Dies gilt auch für Inhalte Dritter, die über dieses Angebot zugänglich sind.

Computer-Aided Automatic Construction of Strut-and-Tie Models

Génération automatique de modèles conformes à l'analogie du treillis

Automatisches Entwickeln von Stabwerkmodellen

Argiris HARISIS

Consulting Engineer
University of Patras
Athens, Greece

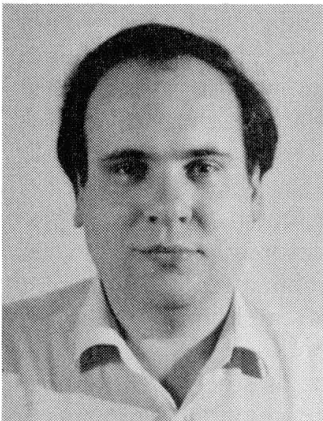

Argiris Harisis, born 1958, received his Civil Engineering Diploma from the University of Patras, and his M.Sc. in Civil Engineering from the University of Toronto (1986). He is now a consulting engineer specializing in computer applications, and a Ph.D. candidate in Structural Engineering at the University of Patras.

Michael N. FARDIS

Prof. of Civil Eng.
University of Patras
Patras, Greece

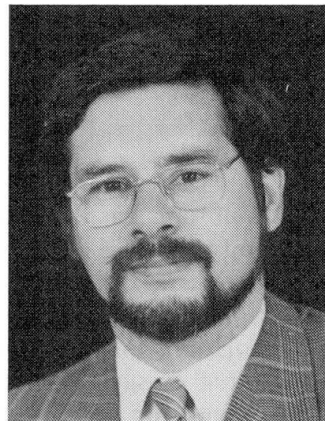

Michael N. Fardis, born 1949, holds an M.Sc. and a Ph.D. from the Civil Engineering Department at the Massachusetts Institute of Technology, where he served as Assistant and Associate Professor from 1979 to 1983. He is now a Professor of Concrete Structures at the University of Patras.

SUMMARY

A multi-step algorithm is presented for the automatic construction of strut-and-tie models of in-plane loaded structural concrete plates. The algorithm is implemented in a user-friendly post-processing mode into a plane-stress linear elastic finite element program, and results are compared to manually constructed strut-and-tie models.

RÉSUMÉ

Cet article présente un algorithme destiné à générer automatiquement des treillis conformes à l'analogie, en vue de l'étude de structures planes en béton. Pour faciliter l'utilisateur, l'algorithme est muni d'un système de post-processing qui l'amène dans un programme d'éléments finis linéaires-élastiques exprimant les contraintes dans le plan. Les résultats obtenus sont comparés à des modèles de treillis dessinés sans l'intervention de l'ordinateur.

ZUSAMMENFASSUNG

Ein Algorithmus zur automatischen Entwicklung des Stabwerkmodells einer Stahlbetonscheibe wird vorgestellt. Dieser Algorithmus ist in benutzerfreundlicher Weise in einem linear-elastisch Finite Elemente Programm zur Berechnung der ebenen Beanspruchung eingebaut. Die Ergebnisse werden mit manuell aufgestellten Stabwerkmodellen verglichen.



1. INTRODUCTION

Recent years have seen the emergence of Strut-and-Tie models as a powerful general approach for the rational and consistent design of structural concrete plates and of two-dimensional regions of static or geometric discontinuity (the so-called D-regions) [1], [2]. Strut-and-Tie models have been originally proposed and developed as a hand-calculation design procedure, in which the structural engineer uses his experience and intuition to draw load paths through the structure in the form of a (usually statically determinate) truss, which is then analysed for the design loads and proportioned according to the applicable Code and to other appropriate rules of practice. In the manual exercise of the construction of the Strut-and-Tie model the engineer may be aided by knowledge of the magnitude and of the directions of principal stresses, obtained by a linear Elastic plane-stress Finite Element analysis of the structural concrete plate or D-region under the design loads. The Struts-and-Ties of the model may then be drawn collinear to the resultants of the principal stresses. However, even when such Finite Element results are available, development of a Strut-and-Tie model for a nontrivial case requires from the designer not only a certain experience and expertise but also considerable time. This may work against the wide acceptance of this new and powerful design tool by the Structural Engineering community, and in favor of the old-fashioned detailing rules-of-thumb advocated by traditional Codes of practice. This is more so as a high design cost for structural concrete plates and discontinuity regions is not economically justifiable, as they are of relatively low cost and of the one-of-a-kind type.

Development of computational tools for the construction of Strut-and-Tie models will reduce the total design time and cost, and therefore may contribute to their more widespread application. To date, and despite the fact that Strut-and-Tie models have drawn considerable attention in recent years, progress in this direction has been limited. As a notable exception, researchers at ETH have developed computational algorithms for the automatic verification of the nodes of a Strut-and-Tie model [3], and for the selection of such a model so that the total weight of steel in the ties is minimized [4]. Nevertheless, selection of the topology of the Strut-and-Tie model still remains a manual task. In the present paper an attempt is made to develop and apply a computational algorithm that automatically generates the topology of Strut-and-Tie models. Development of such an algorithm is facilitated by the fact that the primary information normally used by the engineer to sketch a Strut-and-Tie model, i.e. the stresses obtained from a Finite Element Analysis, is in a systematic digital form that can be directly processed by the computer for further utilization.

2. ALGORITHM FOR THE SELECTION OF THE STRUT-AND-TIE TOPOLOGY

The first stage of the proposed algorithm consists of a linear Elastic Finite Element Analysis of the two-dimensional element or region, subjected to the force and displacement Boundary Conditions of the problem. The Finite Element mesh should be relatively fine and is defined by automatically generated nodes with user-selected constant spacing in the two orthogonal directions x and y . The Analysis yields nodal stresses, by averaging over the neighboring elements, and from them computes (and plots, if the user so desires) the magnitude and the direction of the principal stresses, σ_1 and σ_2 , at the nodes. Two databases are then formed, one referring to the positive principal stresses and the other to the negative ones. The generic record in each database includes the coordinates x and y of the node, the value of σ_1 or σ_2 there, and the angle θ_1 and θ_2 between its direction and axis x . Using these databases, the program performs the following tasks, separately for the positive and the negative stresses :

- 1) It identifies the group of nodal points where the value of the principal stress of interest (positive or negative) lies within a certain user-specified range of values with respect to the mean value of this stress over the entire two-dimensional region, e.g. the group of points where this stress exceeds the mean value by a user-specified multiple of the standard deviation of the stress in question (positive or negative) within the two-dimensional region, but not by more than another such user-specified multiple. In this way the points with relatively high nodal stresses are identified, irrespective of their location in the two-dimensional region.

2) The points in the group identified in 1) above are ordered according to the magnitude of the corresponding angle θ_i ($i=1$ or 2), as this angle varies between 0° to 180° . In other words, the sample histogram (cumulative distribution function) of θ_i is constructed. Next we compute the difference between successive angles in this ordering, which is inversely proportional to the derivative of the histogram (i.e. to the probability density function) of θ_i . A range of angles where this difference is small (i.e. where the probability density function assumes high values) consists of points where the principal stress in question (positive or negative) not only assumes relatively high values but also has nearly parallel directions. So, if they are close, such points may form a strut (for negative stresses) or a tie (for positive). A user-specified number N of groups is formed, covering the entire range of angles between 0° and 180° , each group bounded by two successive local maxima of the difference between the angles θ_i (i.e. by two successive local minima of the probability density function of θ_i). To avoid cases of very small subgroups between two local maxima at almost equal values of θ_i , the variation of these differences is smoothed, by taking their 10-point moving average. In this way closely spaced local maxima merge into a single one.

3) All pairs of points in each group of nearly parallel principal stresses formed in 2) above, are examined for geometric proximity, by comparing the distance of the two points in the group to a certain percentage of the maximum size of the two-dimensional region. In this way each group is partitioned into subgroups of neighboring points with nearly parallel principal stress directions.

4) Provided that it contains a minimum number of points, each subgroup is replaced by a provisional straight-line strut or tie. This straight line passes through the center of gravity of the group points weighted by the value of the principal stress of interest (i.e. positive or negative). Its direction is chosen to coincide with the average principal stress direction of the points in the group, again weighted as above. An option has been included for turning the direction of the ties (or of some of them) to the closest one among a set of user-preferred reinforcement directions (e.g. at 0° , 45° , 90° , or 135° to the x-axis).

5) The provisional struts and ties are replaced by final ones, which form a statically determinate truss consisting of triangles. This is accomplished by finding triads of neighboring points of intersection of three different struts or ties, merging these three points into a single one, and shifting accordingly the corresponding struts or ties. Ties which have originally been arranged to be parallel to one of the pre-defined directions mentioned above (i.e. at 0° , 45° , 90° , or 135°), may be excepted from this shifting operation. Concentrated applied loads or reactions are also included in this part of the algorithm as struts or ties of fixed direction and position.

The algorithm has been implemented in a FORTRAN program that runs under DOS. Both the algorithm and the Finite Element program have been installed on IBM-compatible PC/XT's, and PC/AT's.

3. APPLICATION EXAMPLES

The computational procedure described above is applied to three simple examples: a) A simply supported deep beam with $l/h=2.0$, subjected to a concentrated force at midspan (Fig.1); b) a simply supported deep beam with $l/h=1.56$, with a square perforation extending over $h/3$ near the left support, subjected to a concentrated force at a distance $l/7$ to the right of midspan (Fig. 2, and [1], [4]); and c) the D-region of a stepped beam (Fig. 3) extending to both sides of the step by one beam depth, subjected to pure bending [1]. The Finite Elements used for the analysis were 8-noded square ones, with side about equal to one tenth of the maximum height of the two-dimensional region.

In the first problem the primal group of principal tensile stresses formed by step 1 of the algorithm was chosen to include all stresses exceeding the mean value of the principal tensile stresses by two standard deviations, whereas that of principal compressive stresses was selected to cover all compressive stresses from half a standard deviation below the mean (principal compressive) stress to infinity. For a user-specified maximum number of compressive and tensile stress subgroups equal to 3 each, the Strut-and-Tie model in Fig. 1 was finally obtained. This figure, and the ones to follow, shows the struts by dotted lines, and the ties by continuous ones. In addition, it shows as points the



centroids of the stresses which correspond to the nearby strut or tie.

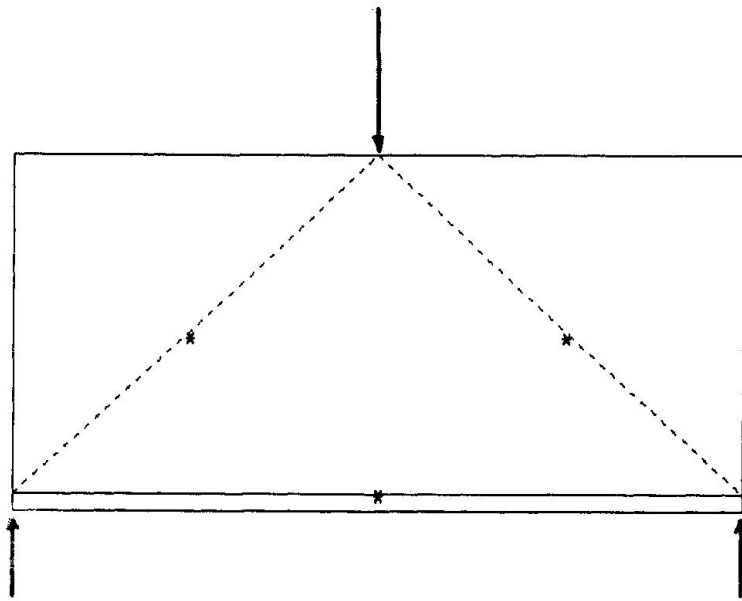

Fig.1 Strut-and-Tie Model for a deep beam

In the second problem the primal groups of principal compressive stresses has been selected as in the first problem, whereas that of the principal tensile stresses has been chosen to include all stresses exceeding the corresponding mean value. For a user-specified maximum number of subgroups of compressive and tensile stresses equal to 4 and 3 respectively, the Strut-and-Tie model is as shown in Fig. 2a. This model is almost identical to the simplest Strut-and-Tie models manually drawn for this problem in [1] and [4].

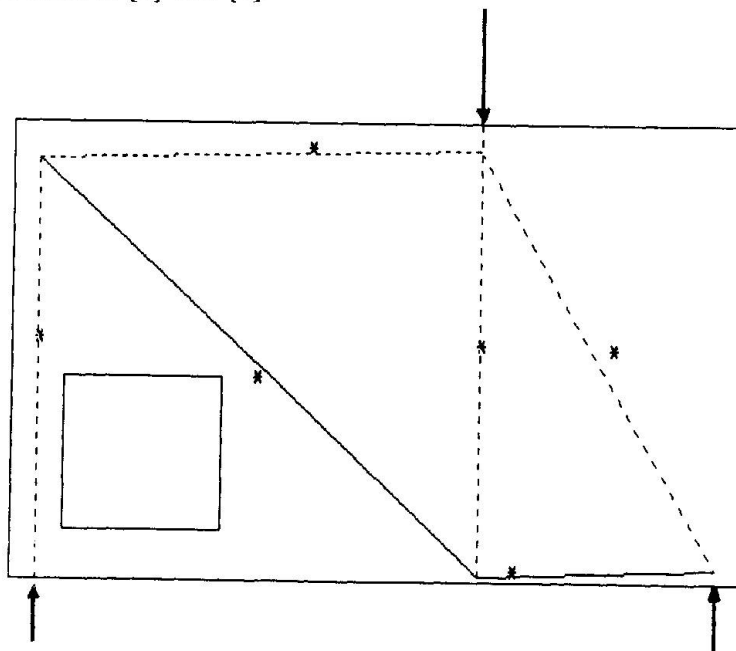

Fig.2 Strut-and-Tie Model for deep beam with perforation

In the third problem, the primal group of principal compressive stresses was chosen as in the previous two problems. A similar selection was made for the group of principal tensile stresses. The

partitioning user had specified each of these groups into a maximum number of 4 subgroups of the type of step 2) of the algorithm. This latter step produced only 2 such subgroups for each type of stresses, which were further partitioned into 3 subgroups of neighboring points in Step 3) of the algorithm. The final Strut-and-Tie model, shown in Fig. 3a, is stable only for the specific loads of the problem. The same holds for the more refined Strut-and-Tie model proposed for this case in [1]. So, this Strut-and-Tie model can be analysed only by equilibrium of the nodes, and not by a general purpose computer program based on the Direct Stiffness Displacement approach. To make the truss stable, the user should insert additional Struts-and-Ties to the model. An extension of the present algorithm to automatically augment the Strut-and-Tie model in such cases is currently under development.

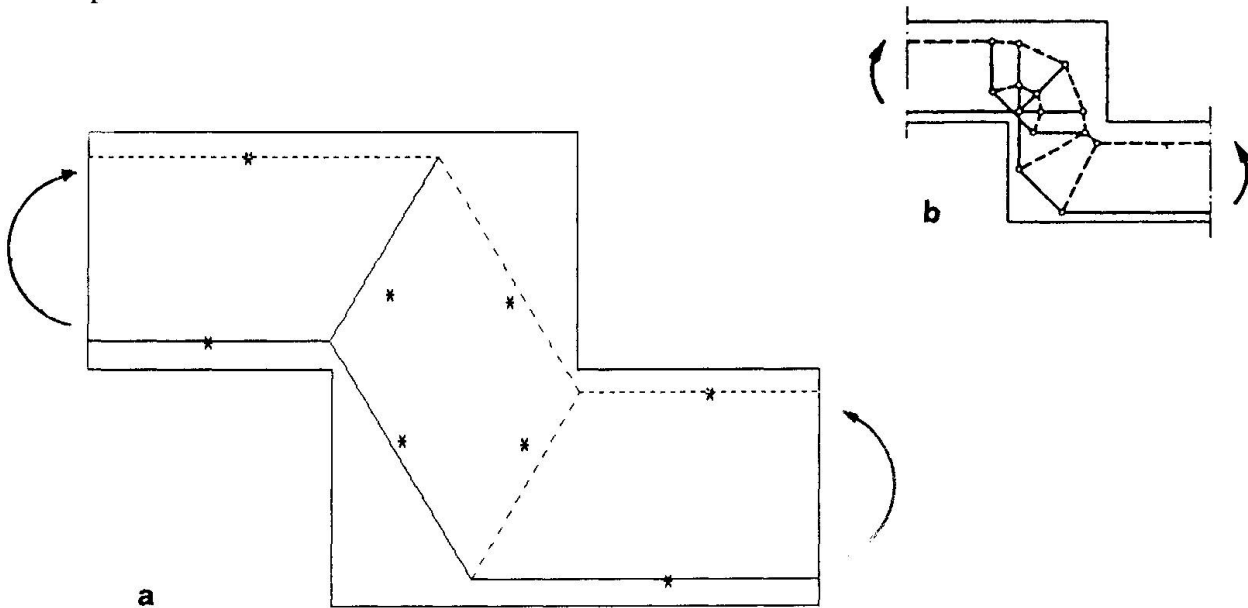

Fig.3 a) Strut-and-Tie Model for stepped beam; b) Strut-and-Tie Model after [1].

The automatic construction of the Strut-and-Tie model in each one of the 3 examples herein required less than 1 min. of computer time on a PC/AT. (To be compared to the few minutes required for the Finite Element Analysis of each problem on the same computer). This time is relatively short, allowing the engineer to try various alternative selections of user-specified parameters in order to improve or refine the Strut-and-Tie model.

REFERENCES

1. SCHLAICH J., SCHÄFER K., and JENNEWEIN M., "Toward a Consistent Design of Structural Concrete", *PCI Journal*, 32, No 3, 1987, 74-150.
2. BREEN J.E., "Why Structural Concrete", Introductory Report, IABSE Colloquium "Structural Concrete", Stuttgart, April 1991.
3. ANDERHEGEN E., and SCHLAICH M., "Computer-aided Design of Reinforced Concrete Structures Using the Truss Model Approach", *Proc., 2nd Int. Conf. on Computer-Aided Analysis and Design of Reinforced Concrete Structures*, Zell-am-See Austria, 539-550, Apr. 1990,
4. SCHLAICH M., and ANAGNOSTOU G., "Stress Fields for the Nodes of Strut-and-Tie Models", *Jour. of Struct. Division, ASCE*, V. 116, No. 1, Jan. 1990, 13-23.

Leere Seite
Blank page
Page vide