

Design of timber structures

Autor(en): **Larsen, Hans Jørgen**

Objektyp: **Article**

Zeitschrift: **IABSE reports = Rapports AIPC = IVBH Berichte**

Band (Jahr): **65 (1992)**

PDF erstellt am: **22.07.2024**

Persistenter Link: <https://doi.org/10.5169/seals-50055>

Nutzungsbedingungen

Die ETH-Bibliothek ist Anbieterin der digitalisierten Zeitschriften. Sie besitzt keine Urheberrechte an den Inhalten der Zeitschriften. Die Rechte liegen in der Regel bei den Herausgebern.

Die auf der Plattform e-periodica veröffentlichten Dokumente stehen für nicht-kommerzielle Zwecke in Lehre und Forschung sowie für die private Nutzung frei zur Verfügung. Einzelne Dateien oder Ausdrucke aus diesem Angebot können zusammen mit diesen Nutzungsbedingungen und den korrekten Herkunftsbezeichnungen weitergegeben werden.

Das Veröffentlichen von Bildern in Print- und Online-Publikationen ist nur mit vorheriger Genehmigung der Rechteinhaber erlaubt. Die systematische Speicherung von Teilen des elektronischen Angebots auf anderen Servern bedarf ebenfalls des schriftlichen Einverständnisses der Rechteinhaber.

Haftungsausschluss

Alle Angaben erfolgen ohne Gewähr für Vollständigkeit oder Richtigkeit. Es wird keine Haftung übernommen für Schäden durch die Verwendung von Informationen aus diesem Online-Angebot oder durch das Fehlen von Informationen. Dies gilt auch für Inhalte Dritter, die über dieses Angebot zugänglich sind.

EC 5: Design of Timber Structures

EC 5: Calcul des structures en bois

EC 5: Bemessung von Holztragwerken

Hans Jørgen LARSEN

Civil Engineer
Build. Res. Inst. SBI
Hørsholm, Denmark

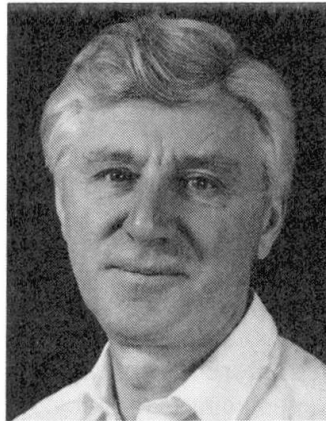

Hans Jørgen Larsen, born 1935. Professor Danish Technical University (1960–74) and Aalborg University Centre (1974–81). Director SBI 1981–. Research in Timber Structures. Active in International Standardization and Code work: CIB W18, ISO, CEN, and Eurocodes.

SUMMARY

An overview is given of the work on Eurocode 5, Design of Timber Structures, with special emphasis on how the effect of moisture content and load duration is treated and on new design principles for e.g. notched beams, columns, trussed rafters and joints. The CEN work on supporting standards is treated briefly.

RESUME

Un survol de l'Eurocode 5 est présenté. On examine en particulier les effets dues à l'humidité et à la durée de charge ainsi que les nouvelles méthodes de calcul en ce qui a trait aux poutres entaillées, aux poteaux, aux fermes et aux assemblages. On aborde brièvement le travail du CEN sur les normes connexes.

ZUSAMMENFASSUNG

Es wird ein Überblick über die Arbeit am EC 5, Bemessung von Holztragwerken, gegeben, von dem der anschließende Entwurf vorliegt. Das Schwergewicht liegt dabei auf der Behandlung der Auswirkungen des Feuchtigkeitsgehalts und der Lasteinwirkungsdauer, sowie auf neuen Bemessungsgrundlagen z.B. für eingekerbte Balken, Stützen, Trägerroste und Verbindungen.



1. DRAFTING

1.1 Eurocode 5, Part 1

The basis for Eurocode 5 is the CIB Structural Timber Design Code, 1983, prepared by the CIB Working Commission W18, Timber Structures [1]. The CIB Code and most of the changes made when shaping it into the present version of Eurocode 5 have been discussed in CIB W18 and are documented in the proceedings from its meetings. For a complete list of papers readers are referred to [2].

A first version of Eurocode 5, Design of Timber Structures, was published by the Commission of the European Communities in 1987 and was out for national comments with a commenting period ending April 1989. The comments were collated and discussed with representatives of the member states of the EEC (and observers from EFTA) in April - June 1990. Based on the comments and the discussions, redrafting was started, but the work was stopped for about 15 months because of the problems with the transfer of the work to CEN.

The work was resumed by 1st September 1991 under a contract with CEN. Thanks to a very cooperative spirit in CEN/TC 250/SC 5 a draft ENV for Eurocode 5, Part 1, General Rules and Rules for Buildings, was finalized by 1st May 1992, and it is now in the process of being adopted as an ENV.

ENV's have no legal status per se, but it is hoped by the Commission that the member states will accept the use of the Eurocode ENV's as alternatives to the existing national standards or accept them as national standards. (For some materials, e.g. timber, some countries have very outdated design standards or none at all). An EN, replacing national standards, will probably be available around the turn of the century.

The redrafting was done by a project team with the following members: H.J. Larsen (DK, convenor), Erik Aasheim (N), Ario Ceccotti (I), Jürgen Ehlbeck (D), and John Sunley (UK). The team was assisted by Frédéric Roug r (F) and Peter Ross (UK) as technical secretary. During various stages of the drafting also Pierre Bonnet (F), Heinz Br ninghof (D), Philippe Crubil  (F), and Pedro de Sousa (P) participated.

1.2 Eurocode 5, Part 2: Bridges

The work on Part 2 has not yet really started. It is envisaged that this part will be on the programme of work for 1993-1994. It will be coordinated with the work on concrete and steel bridges. It will probably be rather a slim volume.

The members of the project team for bridges are: J. Gehri (CH, convenor), J. Kuipers (NL), R. M kipuru (SF), and J. Marcroft (UK), with P. Ross (UK) as secretary.

1.3 Eurocode 5, Part 10: Fire Design

A draft for Part 10 was published in April 1990. It was prepared by a group set up by the Commission and it had worked rather independently, putting greater weight on coordination with the other Part 10's than with Eurocode 5, Part 1. The draft has been criticized for being too complicated, for repeating requirements given in Eurocode 5, Part 1 (and not always being completely identical to those of Part 1), and for setting stricter requirements than has been common, especially by using strength values corresponding to a temperature of 100 C instead of, as is now usual (and probably incorrect), to room temperature.

The members of a new project team (appointed by SC 5 to ensure compatibility with Part 1) are: H. Hartl (A, convenor), G. Hall (UK), M. Kersken-Bradley (D), J. Majamaa (SF), and M. Sagot (F), with J. K nig (S) as secretary.

1.4 Further Parts

No further parts are envisaged. It should be possible to design all timber structures with the three parts mentioned.



1.5 Supporting Documents

Eurocode 5 makes reference to - or presumes the existence of - a large number of supporting standards: on actions, products, testing and evaluation of test results, etc. Most of these are in preparation in other CEN Technical Committees, especially

CEN TC 38 - Durability of Wood and Related Materials: Standards on hazard classes of use, natural durability and wood preservation.

CEN TC 103 - Adhesives for Wood and Derived Timber Products: Standards covering the classification and performance requirements of adhesives for structural applications for both solid timber and glued laminated timber, including test methods for assessing adhesives.

CEN TC 112 - Wood Based Panels: Standards on wood-based panels (plywood, particle board and fibre board), product standards, performance requirement standards, testing standards, etc.

CEN TC 124 - Timber Structures: The responsibility for drafting standards on solid timber is divided between two main committees, TC 124, which covers structural use, and TC 175, which covers non-structural use. TC 124 essentially supports Eurocode 5 (and the essential requirement on mechanical resistance and stability) and covers supporting standards on grading, timber sizes, glued laminated timber and connectors. In addition, it covers test methods for all structural applications.

The work on the supporting standards is impressive. About 150 standards are in course of preparation, of which more than 40% will be available by the end of 1992 and further 40% by the end of 1993. A list of Eurocode 5 related European standards is given in [4].

1.6 A Conflict: Simple or Sophisticated

In drafting a code there is always a conflict between those who want very simple, "user-friendly" codes (and the representatives of some countries maintain that the qualifications of their designers, especially those engaged in the design of timber structures, require very simple codes) and those who want sophisticated and detailed codes, making it possible to use timber in an optimal way in all structures. Pressure for complicated codes often comes from researchers, who want to see their latest research results incorporated in the codes.

Generally, the motto has been: simplify; avoid creating barriers to the use of timber! But international codes will generally be more complicated than national ones because they have to cover a wider range of structures and materials, and different traditions for detailing, workmanship, etc.

An example: For domestic floors rather complicated stiffness requirements and verification methods have been introduced. In most countries there are simple calculation rules or rules of thumb to avoid discomfort due to vibrations or springiness. But since these rules are linked to national traditions for materials, distances between beams, jointing methods, etc, they may work well in one country but lead to completely unsatisfactory floors in another.

1.7 A Code for Designers or for Code-writers?

In principle, Eurocode 5 contains all rules necessary for the design of timber structures. It is not a code for code-writers, but for designers. However, its style is different from most of today's timber codes: it contains only the "legal" rules, not the text-book material and design aids given in most national codes. For example, no values are given for the free column length for different support conditions; this is a general problem of structural mechanics with which the designer is assumed to be familiar. The drafting group for Eurocode 5 has felt it beyond its responsibility (and capacity) to produce all the design aids that are needed for use in practice. That is left to national authorities, institutes, suppliers, etc. It is also assumed that somebody will write the text-books needed for teaching students and professionals to use Eurocode 5, taking the national traditions into account.



2. BASIS OF DESIGN

2.1 General

The basis of design - the design philosophy - is given in a chapter that is the same in all Eurocodes except for some material-dependent additional clauses. The most important of these are mentioned below.

2.2 Influence of Load Duration and Moisture Content, Ultimate Limit States

The properties of timber and wood-based materials are highly dependent on the duration of the actions and on moisture content and variations. This makes it necessary to have a precise definition of characteristic values. For all properties related to ultimate limit states (strength values, moduli of elasticity and density) they are defined as 5 percentiles determined by standardized short-term tests (taking about five minutes) under reference conditions (20°C, 65% relative humidity and a precisely described geometry).

The design values, X_d , are derived from the characteristic values, X_k , as $X_d = k_{mod}X_k/\gamma_m$, where k_{mod} is a modification factor taking into account the effect of the duration of load and the moisture content in the structure, and γ_m is a partial safety factor (material factor), see 2.3.

Examples of values of k_{mod} are given in Table 1.

It is required that structures be assigned to one of three *service classes* and the actions to one of five *load duration classes*.

The service classes denoted 1, 2 and 3 are characterized by the temperature and relative humidity of the surrounding air. The average equilibrium moisture content will in most softwood not exceed 12% in Service Class 1 and 18-20% in Service Class 2. In Service Class 3 the moisture content may be higher.

There are five load duration classes: Permanent, Long-term (up to 10 years), Medium-term (less than 6 months), Short-term (less than one week), and Instantaneous. Depending on local conditions, snow is either Medium-term or Short-term.

Service Class	Solid and Glued Laminated Timber, and Plywood		Particle Board and OSB, medium grades Fibre Board, high grades		
	1 and 2	3	1	2	3
Load Duration Class					
Permanent	0.60	0.50	0.30	0.20	not relevant
Long-term	0.70	0.55	0.45	0.30	relevant
Medium-term	0.80	0.65	0.65	0.45	
Short-term	0.90	0.70	0.85	0.60	
Instantaneous	1.10	0.90	1.10	0.80	

If a load combination consists of actions belonging to different load duration classes, k_{mod} should be chosen corresponding to the action with the shortest duration, e.g. for dead load and for a short-term load, k_{mod} corresponding to short-term load is used.

Table 1 Examples of k_{mod}

2.3 Partial Coefficients, Ultimate Limit States

It is the responsibility of the national authorities to prescribe the partial coefficients. The Eurocodes, however, give a recommended set of values. This set is not based on a rational basis, as for example safety index calculations.

The load factors are the result of compromises in prestandardization bodies like the Comité Euro-International du Béton (CEB). The recommended partial coefficients on actions are for most timber structures the same as for steel and concrete (1.0/1.35 for favourable/unfavourable permanent actions and 1.5 for variable actions). Reduced partial coefficients (1.0/1.2 and 1.35) may, however, be applied for one-storey buildings that have moderate spans and are only occasionally occupied (storage buildings, sheds, greenhouses, and buildings and small silos for agricultural purposes), ordinary lighting masts, light partition walls and sheeting. The ratio γ_Q/γ_G is rather low (~ 1.1). A ratio of about 1.3 would have ensured a more uniform reliability level.

A material factor of $\gamma_M = 1.3$ is proposed for most materials. This value has been estimated on the basis of a calibration taking the existing codes as benchmark: Generally, the safety factors in the existing codes are about 2.5 (e.g. a long-term factor of about 0.6 or 9/16 and an overload factor of about 1.33). The proposed values give a global safety of 2.70 for a structure with dead load only, 2.60 for one variable long-term load only, and 2.30 for a structure with medium-term load (e.g. snow).

3. MATERIALS

3.1 Solid Timber

- Timber shall be strength graded mechanically in accordance with *EN 519: Structural Timber Grading-Requirements for Machine Stress Graded Timber and Grading Machines* - or visually. In the latter case the grading standards shall fulfil the minimum requirements given in *EN 518: Structural Timber - Grading - Requirements for Visual Strength Grading*. There are no compulsory grading standards: The sawing and grading practices in Europe differ so widely that it has not been possible to agree on one or two European grading standards.
- The tolerances shall be in accordance with *EN 336: Structural Timber - Permissible Deviations*. There are no standardized sizes. It has not even been possible to agree on one or two recommended size series.
- Strength and stiffness values shall be determined by standardized test methods, and the results shall be evaluated by standardized methods. The test specimens shall contain a strength reducing grade determining defect. Here, the European tradition is different from North American practice, where the test specimen is cut at random. For a given grade European test values are therefore lower than North American ones.
- Finger-jointed timber can be used without limitation.
- It is recommended, but not required, that the CEN strength class system in *EN 338, Structural Timber - Strength Classes*, be used.

Strength classes are a means of allocating the same mechanical properties to various combinations of grades and species having similar strength. A strength class system is a major simplification and enhances the appeal of timber for use as a structural material. Although there are reasons why a designer may need to exclude certain species, e.g. for non-structural properties such as durability, all grades and species assigned to a given strength class are assumed to be structurally equivalent. This means that all adjustment factors used in design, e.g. size factors, must be applicable to all grades and species, including visual and machine grades. Strength classes offer the following advantages:

- They encourage the use of timber by reducing the complexity caused by many different grades and species.



- They enable designers with little timber experience to overcome a lack of knowledge of the most widely available and most economical grades and species.
- They allow new grades and species to be offered without changing the specification.
- They enable suppliers to offer the timber that they have in stock.

There is, however, one disadvantage to the use of strength classes, which is that some grades and species may be assigned lower strength properties than their true characteristic values.

The strength class system covers all timber of interest for practice from the weakest (with a characteristic bending strength of 14 MPa) to the strongest hardwoods (70 MPa). Further information on the Strength Class system can be found in [5].

3.2 Glued Laminated Timber

The minimum production requirements are given in *EN 386: Glued Laminated Timber Production Requirements*. There will also be a CEN standard with standard strength classes, and also giving guidelines on how to calculate the strength and stiffness of the members from the properties of the laminations.

Finger jointing of the full cross-section is permitted. For Service Class 3, however, it is required that the fibre direction does not change at the joint as e.g. at frame corners.

3.3 Wood-Based Panels

It is a general requirement that panel products be produced so that they maintain their integrity and strength throughout the expected life of the structures. Further, it is required that the properties be determined from tests described in European standards, and that the test values be evaluated according to standardized methods.

In Eurocode 5 reference is made to European product standards covering plywood, fibre boards, and particle boards (all types, also e.g. oriented strandboard and cement-bonded types). For the most common types these standards give the characteristic properties and no further testing is required.

3.4 Adhesives

Adhesives for structural purposes shall produce joints of such strength and durability that the integrity of the bond is maintained in the assigned service class throughout the expected life of the structure. For the time being only polycondensation adhesives of the phenolic and aminoplastic type (urea, melamine) are covered by standards. Work is going on on caseine adhesives, too, and probably polyurethane and epoxy adhesives will be accepted in near future. These two glues are of special interest for bonding steel to timber.

4. SERVICEABILITY LIMIT STATES

4.1 Fundamental Requirements

The members shall be such as to restrict deflection within limits appropriate to the type of structure, having regard to the possibility of damage to surfacing materials, ceilings, partitions and finishes, and to the functional needs as well as visual requirements. It shall also be ensured that actions that are expected to occur frequently do not cause vibrations that can impair the function of the structure or cause unacceptable discomfort to the users.

4.2 Determination of Deflections and Limiting Values

The final deflection, u_{fin} , under an action shall be calculated as:

$$u_{fin} = u_{inst}(1 + k_{def})$$

where u_{inst} is the instantaneous deflection under an action calculated using the mean value of the appropriate stiffness modulus, and k_{def} is a factor which takes into account the increase in deflection with time due to the interactive effect of creep, initial moisture content and moisture variations.

Examples of the creep factor are given in table 2. For combinations of load, the contribution to the final deflection shall be calculated separately for the different actions.

There are only recommended limiting values for the deflections.

In cases where it is appropriate to limit the instantaneous deflections due to variable actions, a limit of $l/300$ (cantilever $l/150$) is recommended, where l is the beam span or the length of a cantilever. In cases where it is appropriate to limit the final deflection, u_{fin} , a value of $l/200$ (cantilever $l/100$) is recommended.

Material/ load-duration	Service Class		
	1	2	3
Solid timber and glued laminated timber			
Permanent	0.80	0.80	2.00
Long-term	0.50	0.50	1.50
Medium-term	0.25	0.25	0.75
Short-term and instantaneous	0	0	0.30
For solid timber which is installed at or near fibre saturation point and which is likely to dry out under load, the values of k_{def} should be increased by 1.0.			
Plywood except shear:			
Permanent	0.80	1.00	2.50
Long-term	0.50	0.60	1.80
Medium-term	0.25	0.30	0.90
Short-term and instantaneous	0	0	0.40
Particle boards (medium grade) and fibre boards (high grade):			
Permanent	2.25	3.0	
Long-term	1.50	2.0	not
Medium-term	0.75	1.0	relevant
Short-term and instantaneous	0	0.4	

Table 2 Examples of k_{def}

4.3 Residential Floors

For many wooden floors vibrations from walking are a problem. To avoid these, Eurocode 5 imposes restrictions on the deflection caused by a vertical concentrated static load (to avoid problems with the low frequency vibrations caused by a walking person) and on the unit impulse velocity response, i.e. the maximum initial value of the vertical floor vibration velocity caused by an ideal unit impulse (to avoid high frequency components which origin from the impact when the heel contacts the floor surface).

A detailed description of the basis for the requirements and the verification method is given in [6].

5. ULTIMATE LIMIT STATES: BASIC MEMBERS

5.1 General

This chapter covers all basic members loaded in tension, compression, bending, and shear.

Generally the strength verification of individual members shall be based on the assumption of a linear relation between stress and strain until failure because the characteristic values are determined on such a linear relation. For members subjected to combined bending and compression, however, a nonlinear relationship (elastic-plastic) may be used.



In the following, some design aspects relating specifically to timber are mentioned, together with their treatment in Eurocode 5.

5.2 Tension Perpendicular to the Grain

The tensile strength perpendicular to the grain of timber is highly dependent on the stress distribution and the stressed volume (weakest link phenomenon). The characteristic strength is therefore linked to a uniformly stressed reference volume V_0 . For a uniformly stressed volume V the characteristic values are multiplied by $(V_0/V)^{0.2}$.

5.3 Bending

The assumption of linear relation between stress and strain can be very conservative for some cross sections and for combined bending about two principal axes. It is therefore required that the more stringent of the following two conditions be satisfied:

$$\frac{\sigma_{m,x,d}}{f_{m,x,d}} + k_m \frac{\sigma_{m,y,d}}{f_{m,y,d}} \leq 1 \quad k_m \frac{\sigma_{m,x,d}}{f_{m,x,d}} + \frac{\sigma_{m,y,d}}{f_{m,y,d}} \leq 1$$

where $\sigma_{m,x,d}$ and $\sigma_{m,y,d}$ are the design bending stresses about the principal axes, and $f_{m,x,d}$ and $f_{m,y,d}$ are the corresponding bending strengths. For the factor k_m , the following values are tentatively given:

for rectangular sections; $k_m = 0.7$

for other cross sections; $k_m = 1.0$

The question of depth factors has been discussed fiercely. With the present visual grading rules there is undoubtedly a depth effect: the bending strength (and also the tensile strength) decreases with depth (width). Some countries feel this should be taken into account, while others feel that it would be more reasonable to improve the grading rules.

A compromise has, however, been reached. It will be required that testing be done at a depth of 150 mm or more. If smaller depths (h) are used, the test results shall be reduced by the factor $(h/150)^{0.2}$. By the design no reduction is required for depths of more than 150 mm; for depths between 40 and 150 mm a corresponding increase is permitted. For glued laminated timber beams the reference depth is 600 mm and no reduction/increase for other depths is required/permitted.

There will be no factors for length or load configuration, although they undoubtedly have an effect on the load-carrying capacity of the structures that can not be counteracted through grading.

5.4 Shear

In the 1989-version of Eurocode 5 the rules for the shear design of beams of glued laminated timber were very complicated, taking into account the stressed volume, the length of the beam, and the load distribution. This proposal found no support, and a traditional strength verification is permitted.

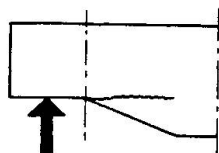

Figure 1 End-notched Beam

For beams notched at the ends, see Figure 1. The design method is based on fracture mechanics. Fracture energy, moduli of elasticity in bending and shear, together with the geometry (beam depth, notch depth and length, and taper) are the governing parameters. The method and its background are given in [7]. For the determination of fracture energy a European test method has been developed.

5.5 Columns

For columns it is required that bending stresses due to initial curvature, eccentricity and induced deflection be taken into account, in addition to those due to any lateral load.

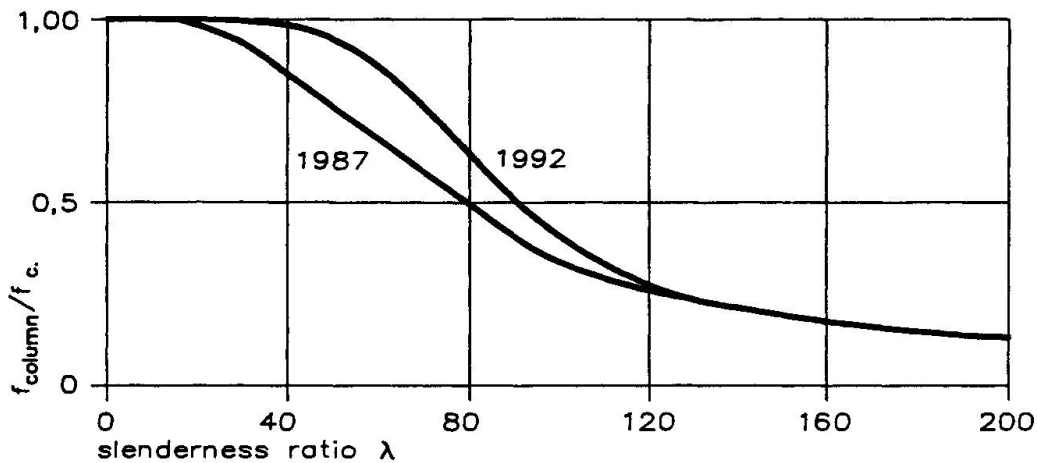

Figure 2 Comparison between the buckling strength of glued laminated columns according to the 1992- and the 1987-version (solid line). From [8]. The column strength is f_{column} , f_c is the compression strength.

In the 1987-version of Eurocode 5 the column design was based on the theory of linear elasticity. For the present version a new design method has been developed, making use of the possibility of plastic deformation of timber subjected to compressive stresses leading to higher ultimate loads, see Figure 2. A direct application of the theory requires time-consuming iterative calculations, and in Eurocode 5 a simple approximation based on the results of these calculations has been introduced. The method is described in [8].

6. ULTIMATE LIMIT STATES: MEMBERS AND COMPONENTS

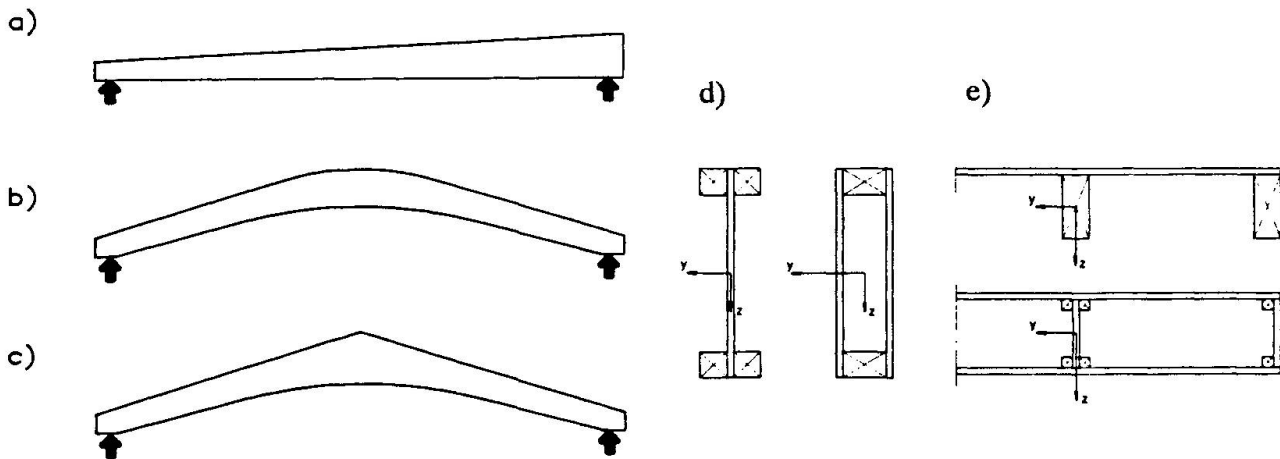

Figure 3 a) Single tapered beam. b) Curved beam. c) Pitched cambered beam. d) Thin-webbed beams. e) Thin-flanged beams.



The section covers

- *Single tapered beams*: The effect of the taper on bending stresses parallel to the surface is taken into account. For the tapered edge, where the stresses are parallel to the surface and not to the grain, a simple failure criterion is given.
- *Double tapered, curved and pitched cambered beams*: The effect of curvature on the stress distribution and on the strength of the laminations (because of the induced bending stresses under production) shall be taken into account. The strength perpendicular to the grain depends on the stress distribution and the stressed volume.
- *Glued thin-webbed beams (I-beams, box-beams)*: Formulae for the stresses are given, together with failure criteria corresponding to tension/compression/bending failures in the flanges, to bending or shear failure in the webs, and to shear between flanges and webs. There are also rules for buckling, allowing postbuckling effects to be taken into account, i.e. first buckling may in many cases be regarded as a serviceability failure.
- *Thin-flanged beams (stiffened plates)*: As for thin-webbed beams.
- *Mechanically jointed beams and mechanically jointed and glued columns (e.g. spaced columns)*: Design formulae are given for most structures of this type that will be met in practice.
- *Trusses and trussed rafters*: The sections in the 1987 Eurocode 5 on those important structures were almost void, which was heavily criticised. Thanks to excellent cooperation between industry and researchers, a comprehensive section has been drafted, covering both the member design and the design of the metal plates in trussed rafters. Furthermore, a production standard has been drafted for CEN. Reference is made to [9].

For trusses which are fully triangulated, have no re-entrant angles in the external profile and have small eccentricities at the supports, a simplified analysis is permitted: The axial forces in the members should be determined assuming that every node is pin-jointed, and the bending moments in single-bay elements on the basis that the end nodes are pin-jointed. The effect of deflection at the nodes and partial fixity at the joints should be taken into account by a reduction of 10% in the support bending moment in elements which are continuous over several bays.

Other trusses shall be analysed as frame structures, where the stiffness of the members and the joints, the influence of any eccentricities or joint slip, and the stiffness of the supporting structure, are taken into account. For trussed rafters it is permissible to increase the bending strength at distinct bending stress peaks by a factor: $k_m = 1.65 - 0.15f_{m,k}$, where $f_{m,k}$ is the characteristic bending strength. The reason for this factor is the reduced possibility of maximum stresses coinciding with maximum defects.

- *Bracing*: Requirements are given for the stiffness and strength of the bracing system.
- *Plane frames*: Rules are given for plane frames, taking into account second order elastic effects (the influence of initial deviations from the geometry and of deformations on the load distribution).
- *Diaphragms*: Rules are given for roof diaphragms and wall diaphragms. For walls there are three possibilities:
 - Testing of prototypes of the wall according to a standardized method.
 - Testing of a standard wall (2.4 m wide) and extrapolation to the actual wall.
 - Calculation according to very simplified code rules.

In principle, the same possibilities apply to roof diaphragms. In practice, however, the design will be based on simplified calculation rules.

7. JOINTS

7.1 General

Designing joints is undoubtedly the most difficult and time-consuming part of the design of timber structures. In Eurocode 5 the section on joints takes up about 20% of the timber-specific text, yet only the most common joint types are covered in detail: nails, bolts, screws. For a number of traditional connectors reference is made to European standards giving specifications and characteristic load-carrying capacities. For proprietary products (special nails, nail plates, and connectors etc.), it is necessary to get European Technical Approvals.

For joints, the design and detailing rules (minimum thicknesses, spacing, end and edge distances) are interrelated and they are treated together.

The general requirements are:

- The characteristic load-carrying capacity shall in principle be based on standardized short term tests
- It shall be taken into account that the load-carrying capacity of a multiple-fastener joint will frequently be less than the sum of the individual fastener capacities.
- The influence of fluctuating load shall be taken into consideration.
- If the load is carried by more than one type of fastener, due consideration shall be given to the influence of differences in stiffness.
- The arrangement of timber joints and the size of the fasteners, spacings, and distances to the ends or edges of the timber, shall be chosen so that the strength is not reduced.
- For forces acting perpendicular to the grain, the influence of stresses perpendicular to the grain shall be taken into account.

7.2 Dowel Type Fasteners

The dowel type fasteners covered by Eurocode 5 are nails, bolts, dowels (i.e. tight-fitting cylindrical elements) and screws.

The load-carrying capacity is determined from expressions first proposed by K.W. Johansen in 1949 in an IABSE publication [10]. The basic material parameters are the embedding strength (bearing strength/crushing strength) under the fastener and the fastener yield moment, and stiff-plastic behaviour is assumed. For timber and plywood, the embedding strength is given in Eurocode 5 as a function of the density. The yield moment is given for ordinary nails and bolts. For other materials, the embedding strength and the yield moment have to be determined by standardized tests.

The resulting expressions are rather complicated, but they were preferred to the approximation given in the 1987-version of Eurocode 5, the argument being that even the approximate expression was so complicated that design aids (tables, or better small programmes) were needed, and then one might as well use the "correct" formulae which imposed fewer restrictions on geometry, combinations of materials, etc.

For large forces, the most efficient jointing method is probably steel gussets nailed or screwed with relatively thin screws - up to 6 mm. The load-carrying capacity of each nail is about 25-40% higher than in timber-to-timber joints, and due to the reduced risk of splitting, the minimum spacings are reduced by about 70%, i.e. the load-carrying capacity per unit area is increased by about 150%.

7.3 Axially Loaded Nails and Screws

There are given values for the withdrawal resistance of ordinary nails and screws. For improved nails (annular ringed shank and threaded nails) and special screws, it is necessary to obtain a European Technical Approval.



8. STRUCTURAL DETAILING AND CONTROL

This chapter gives the necessary requirements for the applicability of the design rules given in the preceding chapters. They relate to materials, joints, assembly, transportation, and erection.

There is also a section on control. It is required that there be a control plan comprising:

- Control of the design.
- Production and workmanship control off and on site.
- Control after completion of the structure.

9. LITERATURE

1. CIB STRUCTURAL TIMBER DESIGN CODE. CIB Report, Publication 66. 1983.
2. PROCEEDINGS OF CIB W18 MEETING 24. Oxford, September 1991.
3. PROCEEDING OF THE 1991 INTERNATIONAL TIMBER ENGINEERING CONFERENCE, London, September 1991, Volume 1.
4. J.G. SUNLEY: CEN Standards on Timber - General Introduction. Paper in [3].
5. A.R. FEWELL: CEN Standards for Strength Classes and the Determination of Characteristic Values.
6. SVEN V. OHLSSON: Serviceability Criteria - Especially Floor Vibration Criteria. Paper in [3].
7. PER JOHAN GUSTAFSSON: Eurocode 5. Draft Design Criteria for Notched Beams. Paper in [3].
8. H.J. BLASS: Design of Columns. Paper in [3].
9. ERIK AASHEIM: Design of Trusses. Paper in [3].
10. K.W. JOHANSEN: Theory of Timber Connectors. IABSE, Publication 9, Bern 1949.