

# Dynamic characteristics of a Chinese monument

Autor(en): **Fang, Dongping / Miyamoto, Yutaka / Iwasaki, Shoji**

Objekttyp: **Article**

Zeitschrift: **IABSE reports = Rapports AIPC = IVBH Berichte**

Band (Jahr): **70 (1993)**

PDF erstellt am: **22.07.2024**

Persistenter Link: <https://doi.org/10.5169/seals-53291>

## **Nutzungsbedingungen**

Die ETH-Bibliothek ist Anbieterin der digitalisierten Zeitschriften. Sie besitzt keine Urheberrechte an den Inhalten der Zeitschriften. Die Rechte liegen in der Regel bei den Herausgebern.

Die auf der Plattform e-periodica veröffentlichten Dokumente stehen für nicht-kommerzielle Zwecke in Lehre und Forschung sowie für die private Nutzung frei zur Verfügung. Einzelne Dateien oder Ausdrucke aus diesem Angebot können zusammen mit diesen Nutzungsbedingungen und den korrekten Herkunftsbezeichnungen weitergegeben werden.

Das Veröffentlichen von Bildern in Print- und Online-Publikationen ist nur mit vorheriger Genehmigung der Rechteinhaber erlaubt. Die systematische Speicherung von Teilen des elektronischen Angebots auf anderen Servern bedarf ebenfalls des schriftlichen Einverständnisses der Rechteinhaber.

## **Haftungsausschluss**

Alle Angaben erfolgen ohne Gewähr für Vollständigkeit oder Richtigkeit. Es wird keine Haftung übernommen für Schäden durch die Verwendung von Informationen aus diesem Online-Angebot oder durch das Fehlen von Informationen. Dies gilt auch für Inhalte Dritter, die über dieses Angebot zugänglich sind.

## **Dynamic Characteristics of a Chinese Monument**

Caractéristiques dynamiques d'un monument chinois

Dynamische Eigenschaften eines chinesischen Baudenkmals

### **Dongping FANG**

Lecturer  
Xian Jiaotong Univ.  
Xian, China

### **Yutaka MIYAMOTO**

Prof. Dr.  
Iwate Univ.  
Morioka, Japan

### **Shoji IWASAKI**

Assist. Prof  
Iwate Univ.  
Morioka, Japan

### **Hideaki DETO**

Assist. Prof  
Iwate Univ.  
Morioka Japan

### **Hiroshi HIKOSAKA**

Prof. Dr.  
Kyushu Univ.  
Fukuoka, Japan

### **Maohong YU**

Prof.  
Xian Jiaotong Univ.  
Xian, China

## **SUMMARY**

The dynamic characteristics of a Chinese monument and the properties of its connectors, three-dimensional finite element methods, were studied. The wooden structure was analysed by a program, the connectors were modeled as flexible elements. Based on the structure's natural frequencies, the coefficients of the flexible elements were determined and the structure's natural frequencies and vibration mode were clarified. The structure's semi-rigid connectors were proven to be advantageous in their aseismic aspects when comparing the structure's earthquake responses with its fixed connectors.

## **RÉSUMÉ**

Les caractéristiques dynamiques d'un monument chinois et les propriétés de ses connecteurs ont été étudiés. La structure en bois a été analysée, les connecteurs étant considérés flexibles dans le modèle. Basé sur la structure des fréquences naturelles, le coefficient de la flexibilité des connecteurs est déterminé, la structure des fréquences naturelles et le mode de vibration ont été clarifiés. La structure semi-rigide des connecteurs offre un avantage antisismique, en comparaison de celles des connecteurs fixes.

## **ZUSAMMENFASSUNG**

Von einem historischen hölzernen Baudenkmal wurden die dynamischen Eigenschaften mittels der Finiten-Elemente-Methode untersucht. Dabei wurde besonderes Augenmerk auf die Modellierung der nachgiebigen Holzverbindungen gelegt. Anhand gemessener Eigenfrequenzen des Gebäudes konnten die Steifigkeiten der Verbindungen kalibriert und so die Schwingungsformen bestimmt werden. Dabei zeigte es sich, dass die nachgiebigen Verbindungen im Vergleich zu steifen Anschlüssen Vorteile bezüglich des Erdbebenwiderstandes aufweisen.



## 1. INTRODUCTION

The 12-meter high Xian City Wall is one of the largest and best-preserved defence architectures built during medieval times in China. The national relic—the Front Tower (Fig.1) over the North Gate of Xian City Wall—was built in the 1370's (Ming Dynasty in Chinese history). This valuable architectural structure is composed of over 6000 wooden components and supported mainly by 36 columns each with an average diameter of 0.55 meter (Fig.2 and Fig.3).

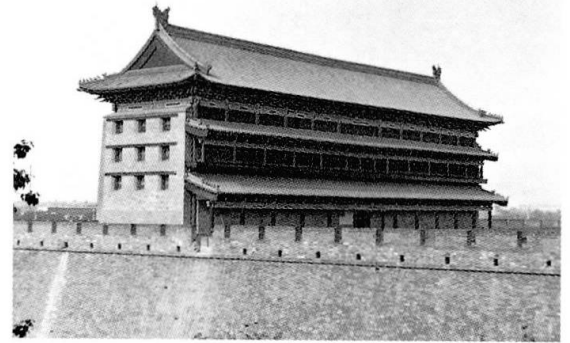

Fig.1 The Front Tower

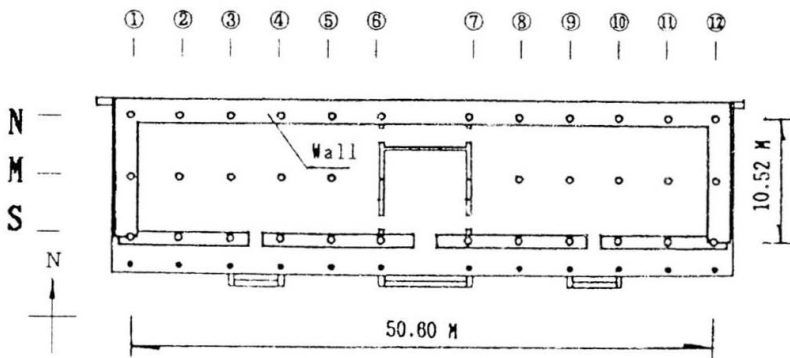

Fig.2 The Plane View

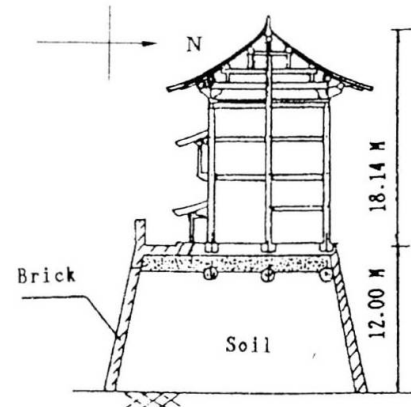

Fig.3 The Elevation

Xian City is located in a seismic zone and several strong earthquakes have occurred during its history. However, the Front Tower survived these calamities. It is therefore significance to study its dynamic characteristics in order to determine the inherent aseismic advantages and to prevent it from being destroyed during any subsequent earthquakes.

In the author's formal work[1], full scale vibration and model tests were carried out in order to determine the natural frequencies of the structure. These were determined to be 1.10Hz and 1.70Hz for basic natural frequencies of symmetrical and asymmetrical vibration mode shapes. In this paper, 3-D FEM dynamic analysis of the wooden structure was undertaken and the Dougong and joggle joint—the components' connecting method, as used in Chinese wooden structures for thousands of years—was modeled as flexible elements. Contrary to general structural analysis methods, Simplex Method was employed to determine the coefficients of the flexible elements in order to cause the calculated frequencies to agree with the tested ones.

After clarifying the natural frequencies and vibration mode shapes, the seismic responses of Middle Japanese Sea Earthquake were also calculated. The connectors were proven to be advantageous in the structure's aseismic aspect.

## 2. FEM MODEL OF THE FRONT TOWER

### 2.1 The Semi-Rigid Connectors and Flexible Element

In Chinese and Japanese wooden structures, the joggle joint (Fig.4) and Dougong (a system of brackets inserted between the top of a column and a crossbeam)(Fig.5) were used as component connectors. In this paper, this kind of semi-rigid connector was described by 3-D flexible elements (Fig.6) and the equation can be expressed as Eq.1.

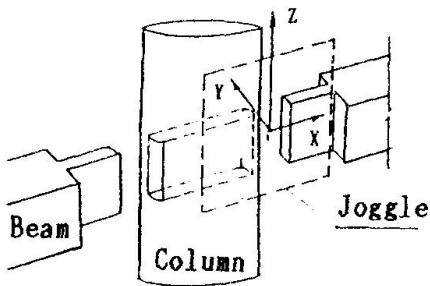

Fig.4 The Joggle Joint

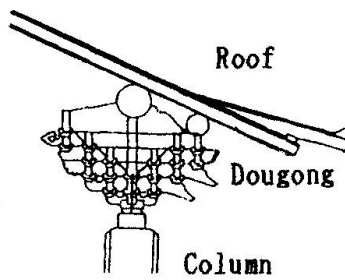

Fig.5 The Dougong

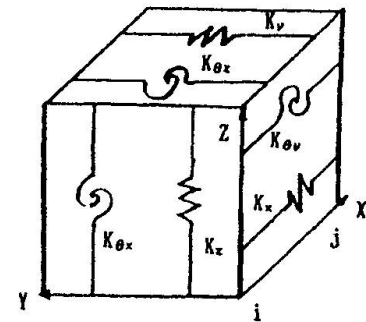
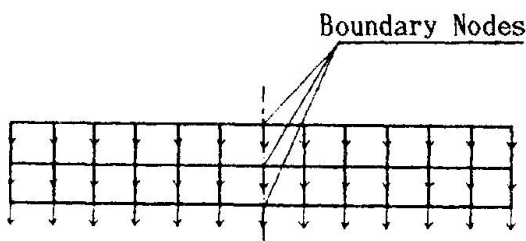

Fig.6 The Flexible Element

$$\begin{Bmatrix} F_{x_i} \\ F_{y_i} \\ F_{z_i} \\ M_{x_i} \\ M_{y_i} \\ M_{z_i} \\ F_{x_j} \\ F_{y_j} \\ F_{z_j} \\ M_{x_j} \\ M_{y_j} \\ M_{z_j} \end{Bmatrix} = \begin{bmatrix} K_x & K_y & K_z & 0 & -K_x & -K_y & -K_z & 0 & 0 & 0 & 0 & 0 \\ 0 & K_{\theta_x} & K_{\theta_y} & 0 & 0 & 0 & 0 & -K_{\theta_x} & -K_{\theta_y} & -K_{\theta_z} & 0 & 0 \\ -K_x & -K_y & 0 & K_x & K_y & K_z & 0 & 0 & 0 & 0 & 0 & 0 \\ 0 & -K_{\theta_x} & -K_{\theta_y} & 0 & K_{\theta_x} & K_{\theta_y} & K_{\theta_z} & 0 & 0 & 0 & 0 & 0 \end{bmatrix} \begin{Bmatrix} \delta_{x_i} \\ \delta_{y_i} \\ \delta_{z_i} \\ \theta_{x_i} \\ \theta_{y_i} \\ \theta_{z_i} \\ \delta_{x_j} \\ \delta_{y_j} \\ \delta_{z_j} \\ \theta_{x_j} \\ \theta_{y_j} \\ \theta_{z_j} \end{Bmatrix} \quad (1)$$

### 2.2 FEM Model and Boundary Condition

Since the Front Tower was symmetrically constructed, the vibration mode shapes were divided into symmetrical and asymmetrical (Fig.7) and half of the structure is modeled



(a) symmetric vibration

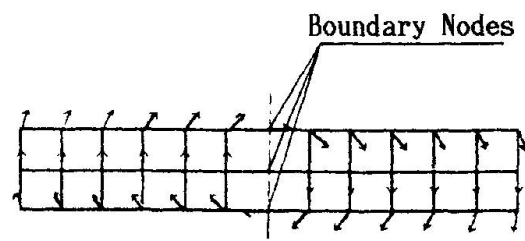

(b) asymmetric vibration

Fig.7 The symmetric and asymmetric vibration shapes of the Front Tower



as Fig.8. The number of beam elements, flexible elements and nodes is 208, 162 and 280, respectively. The value of the flexible elements will be determined afterward. Because the columns of the structure have no other connections with the base stones but are only set upon it, hinges were used as the boundary condition. The nodes located in the symmetrical plane are constrained, as shown in Fig.9.

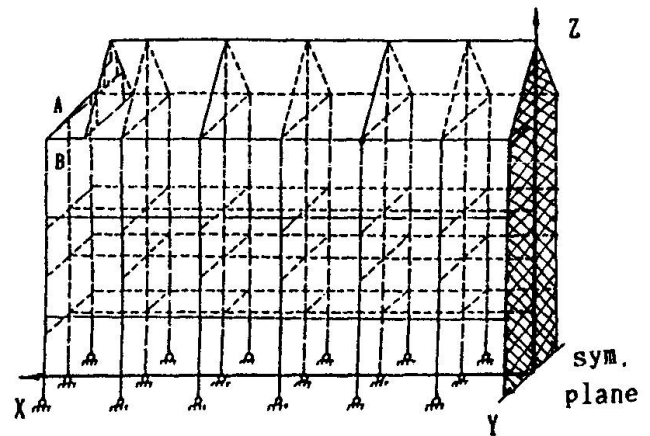

Fig.8 The FEM Model of the Front Tower

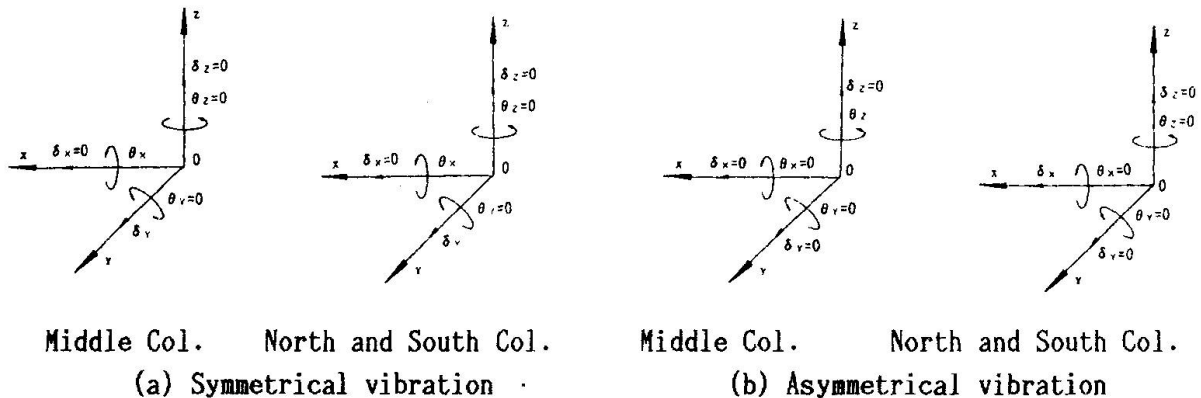

Fig.9 The Boundary Condition of Symmetrical Plane

### 3. DETERMINATION OF THE PROPERTIES OF CONNECTORS

Since the Front Tower is over 600 years old, the elastic properties of each connector are different. It is also not necessary to consider each individual property, because what concerns this study is the global characteristic of the Front Tower. In this paper, the average value of the elastic properties of Dougong ( $K_{TK}$ ) and joggle joints located in x axial direction ( $K_{XA}$ ) and y axial direction ( $K_{YA}$ ) were determined.

In determining the stiffness of 3 kinds of flexible elements by means of the Simplex Method, the object function is formed as follows.

$$OBJ = \sqrt{(F_B - F_{B0})^2 + (F_T - F_{T0})^2} \quad (2)$$

where

$F_B$  : 1st symmetrical natural frequency by means of structural analysis

$F_{B0}$  : 1st symmetrical natural frequency by means of test,  $F_{B0}=1.100$  Hz

$F_T$  : 1st asymmetrical natural frequency by means of structural analysis

$F_{T0}$  : 1st asymmetrical natural frequency by means of test,  $F_{T0}=1.700$  Hz

In each flexible element, let  $K=K_x=K_y=K_z$  and  $K'=K_{\theta_x}=K_{\theta_y}=K_{\theta_z}$ , and start the iteration when



$$\begin{aligned}
 K_{XA} &= 3.0 \times 10^9 \text{ kgf/cm} \\
 K_{YA} &= 3.0 \times 10^9 \text{ kgf/cm} \\
 K_{TK} &= 3.0 \times 10^7 \text{ kgf/cm} \\
 K_{XA}' &= 3.0 \times 10^{11} \text{ kgf/cm}^2 \\
 K_{YA}' &= 3.0 \times 10^{10} \text{ kgf/cm}^2 \\
 K_{TK}' &= 3.0 \times 10^9 \text{ kgf/cm}^2
 \end{aligned}$$

The object function OBJ and  $F_B$ ,  $F_T$  change, as in Fig.10, when the iteration number N increases. The ranges of the connectors' properties which make the OBJ less than 0.02 were as follows:

$$\begin{aligned}
 K_{XA} &= 0.10 \times 10^9 \sim 4.00 \times 10^9 \text{ kgf/cm} \\
 K_{YA} &= 1.59 \times 10^9 \sim 1.97 \times 10^9 \text{ kgf/cm} \\
 K_{TK} &= 2.12 \times 10^8 \sim 2.38 \times 10^8 \text{ kgf/cm} \\
 K_{XA}' &= 5.87 \times 10^{11} \sim 9.77 \times 10^{11} \text{ kgf/cm}^2 \\
 K_{YA}' &= 6.44 \times 10^{10} \sim 9.10 \times 10^{10} \text{ kgf/cm}^2 \\
 K_{TK}' &= 3.16 \times 10^9 \sim 7.17 \times 10^9 \text{ kgf/cm}^2
 \end{aligned}$$

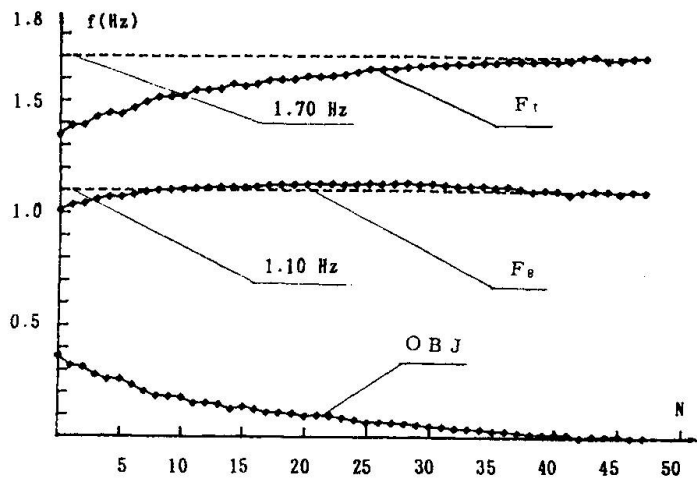

Fig.10 The Iteration of Simplex Method

#### 4. THE DYNAMIC CHARACTERISTICS OF THE FRONT TOWER

By means of the determined properties of the flexible elements, the natural frequencies up to 10th mode (Table 1) and the vibration

Table 1 Natural Frequencies(Hz)

Mode	Symmtr.	Inv. Sym.
1	1.1089	1.7092
2	3.6093	5.6551
3	6.1694	6.7195
4	6.9043	8.1929
5	7.2118	9.2339
6	9.4001	13.0814
7	9.9288	14.7401
8	10.8743	15.1447
9	11.2877	15.9765
10	12.7344	16.9827

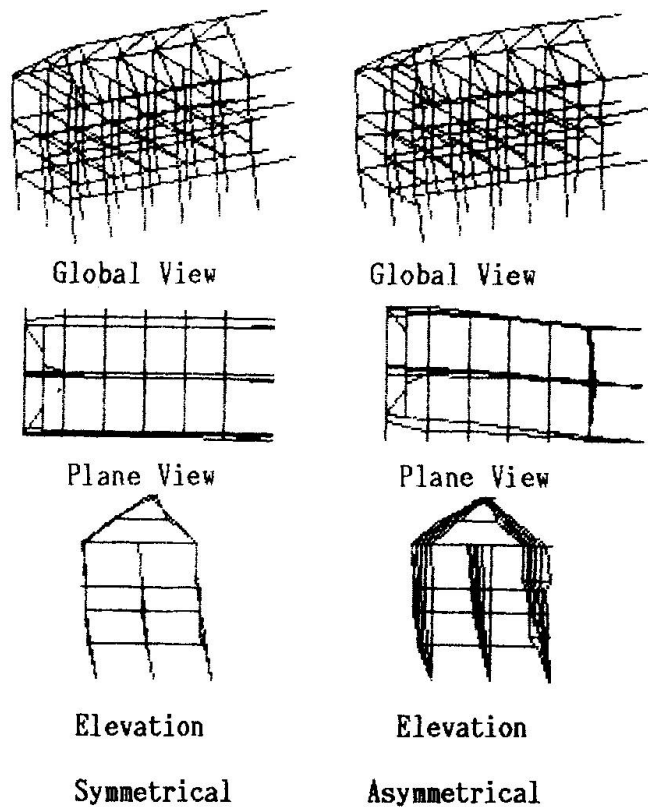
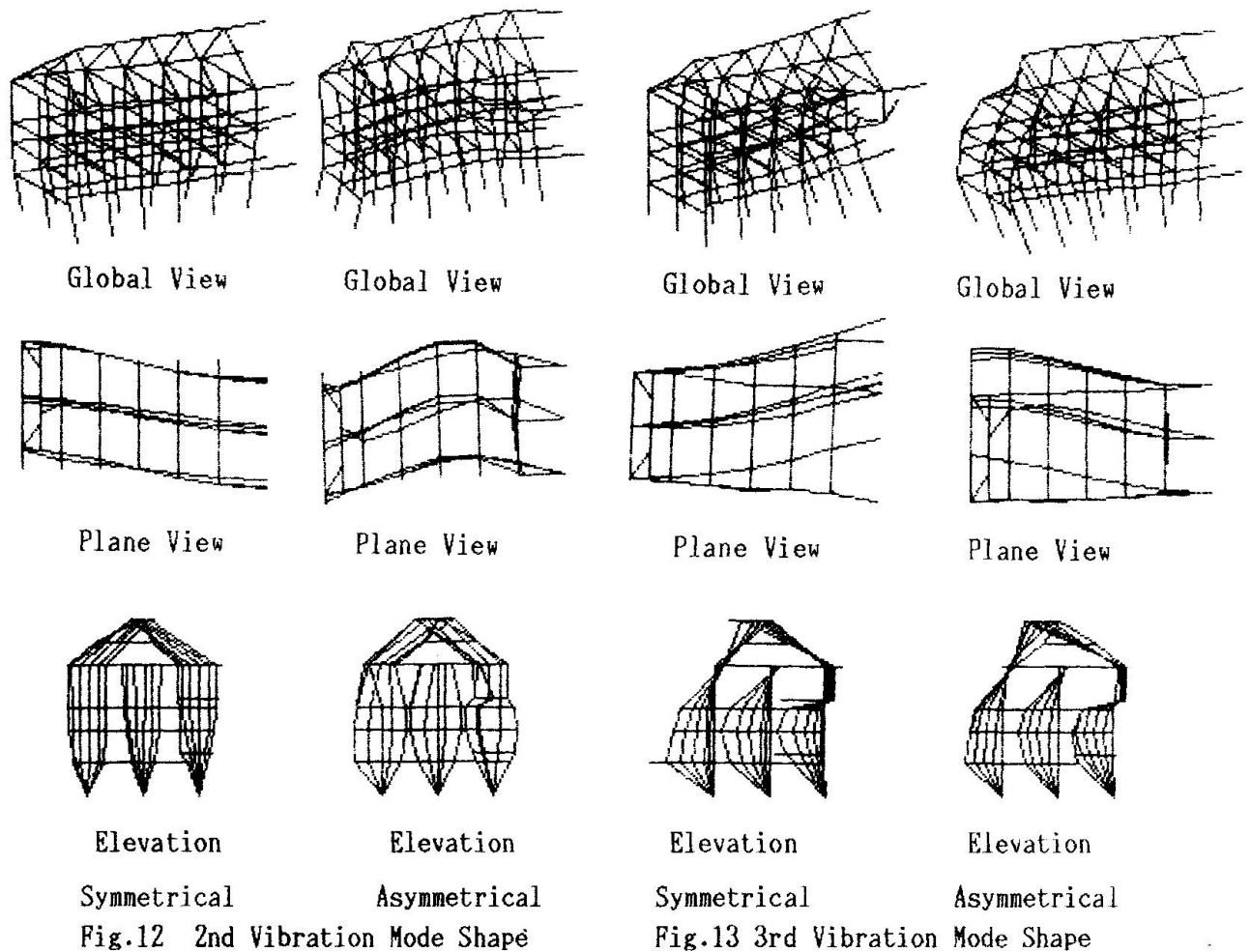
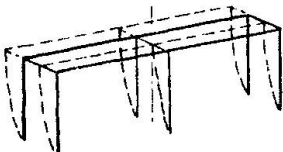
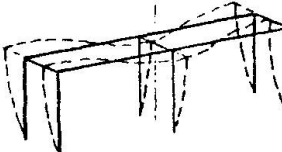
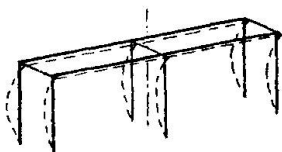

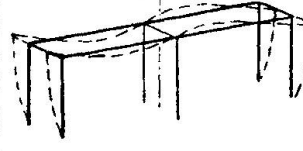



Fig.11 1st Vibration Mode Shape



mode shape up to 3rd mode of both symmetrical and asymmetrical vibrations were calculated. Fig.11, Fig.12 and Fig.13 show the 1st, 2nd and 3rd vibration mode shapes. Referring to the tested results, the natural frequencies and the vibration mode shapes up to 3rd mode of both symmetrical and asymmetrical vibrations are shown in Table 2.

Table 2 The Natural Frequencies and Vibration Mode Shapes

Vibration Mode	1st Mode	2nd Mode	3rd Mode
Symmetric	 1.100 Hz	 2.725 Hz	 6.610 Hz
Inverse Symmetric	 1.700 Hz	 3.100 Hz	 7.200 Hz



## 5. THE SEISMIC EFFECT OF THE SEMI-RIGID CONNECTORS

By means of a 3-D dynamic analysis program (Flow Chart: Fig.14), the structure's earthquake response analysis was undertaken[2].

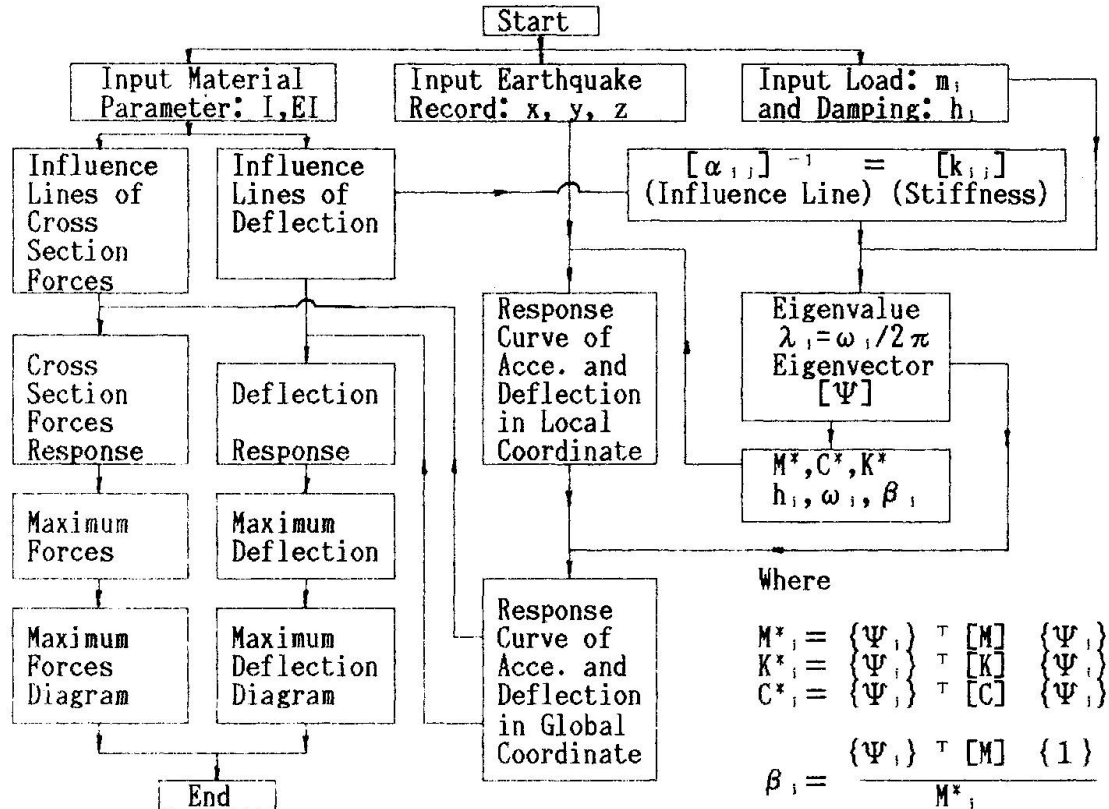

Fig.14 The Flow Chart of Earthquake Response Analysis

In order to understand the effect of the Dougong and joggle joint, the earthquake responses of the Front Tower with the connectors modeled as both rigid and semi-rigid joints were calculated (Fig.14). The deflection and acceleration responses were obtained from node A and the inner force responses were obtained from element B (referring to Fig.8), where the maximum response of the structure was recorded. It

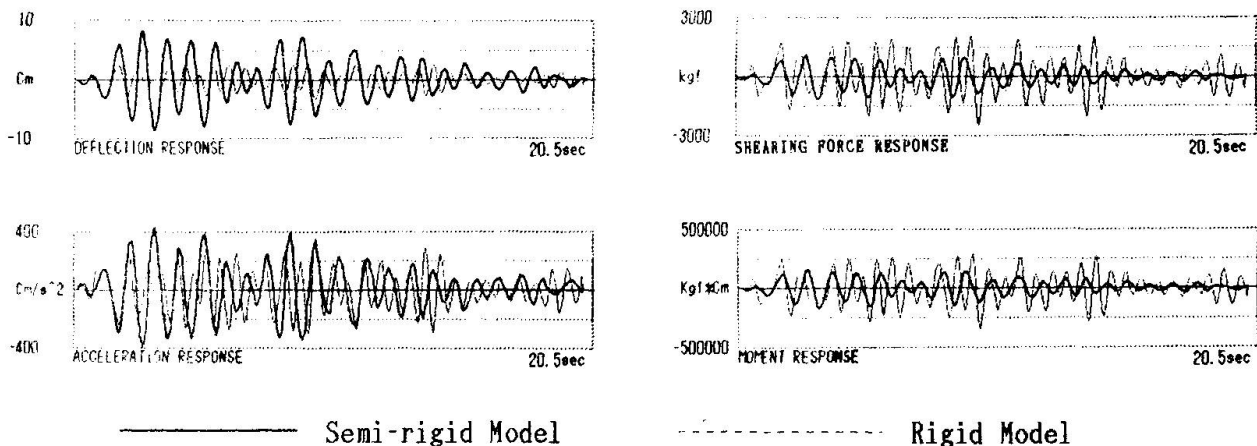

Fig.14 Earthquake Responses of the Front Tower





shows that the deflection response with the joints modeled as semi-rigid is twice that of the rigid modeled joint, and the inner force response is 2/3 that of the rigid modeled joint. Considering that the maximum deflection response is only about 8 cm, it could be said that the semi-rigid connectors offer an advantage for the structure's aseismic qualities.

## 6. CONCLUSION

There are many architectural heritages in the wooden structures of China, Japan and Korea. The understanding of their dynamic characteristics is of importance in structural preservation. The authors have taken years to try to clarify the behavior of the wooden structure's semi-rigid connectors, and, to understand their dynamic characteristics by means of full scale testing, model testing and 3-D FEM analysis[3][4][5].

In this paper, the elastic properties of the Dougong and Joggle joint, and the Front Tower's natural frequencies and vibration mode shapes, were clarified by means of the Simplex Method and 3-D FEM dynamic analysis. The earthquake response analysis shows that the Dougong and joggle joint are aseismic advantages. It should therefore be noted that the connectors should not be strengthened when this kind of valuable architectural structure is being repaired.

## REFERENCE

1. FANG Dongping, et al: Studies on Dynamic and Aseismic Characteristics of an Ancient Chinese Timber Structure, Proc. of Struc. Eng., Vol.38A, JSCE, 1992.3
2. N.Watanabe and Y.Miyamoto: The Method of Time History Earthquake Response Analysis, Gihodo Press, 1985
3. FANG Dongping : Studies on Elasto-plastic Properties, Dynamics and Earthquake Resistance of Wood Structures, Master's thesis, Xian Jiaotong Univ., 1988.4
4. FANG Dongping, et al: A Full Scale Test and Numerical Analysis on Dynamical Characteristics of an Ancient Wood Structure, Proceedings of the International Conference on Structural Engineering and Computation, Beijing, China, 1990.4
5. Fang Dongping, et al: Survey and 3 Dimensional Nonlinear Analysis of A Chinese Ancient Wooden Structure with Base Settlement, Proc. of Struc. Eng., Vol.39A, JSCE, 1993.3