

EC 1: actions induced by cranes

Autor(en): **Sedlacek, Gerhard / Grotmann, Dietmar**

Objekttyp: **Article**

Zeitschrift: **IABSE reports = Rapports AIPC = IVBH Berichte**

Band (Jahr): **74 (1996)**

PDF erstellt am: **22.07.2024**

Persistenter Link: <https://doi.org/10.5169/seals-56087>

Nutzungsbedingungen

Die ETH-Bibliothek ist Anbieterin der digitalisierten Zeitschriften. Sie besitzt keine Urheberrechte an den Inhalten der Zeitschriften. Die Rechte liegen in der Regel bei den Herausgebern.

Die auf der Plattform e-periodica veröffentlichten Dokumente stehen für nicht-kommerzielle Zwecke in Lehre und Forschung sowie für die private Nutzung frei zur Verfügung. Einzelne Dateien oder Ausdrucke aus diesem Angebot können zusammen mit diesen Nutzungsbedingungen und den korrekten Herkunftsbezeichnungen weitergegeben werden.

Das Veröffentlichen von Bildern in Print- und Online-Publikationen ist nur mit vorheriger Genehmigung der Rechteinhaber erlaubt. Die systematische Speicherung von Teilen des elektronischen Angebots auf anderen Servern bedarf ebenfalls des schriftlichen Einverständnisses der Rechteinhaber.

Haftungsausschluss

Alle Angaben erfolgen ohne Gewähr für Vollständigkeit oder Richtigkeit. Es wird keine Haftung übernommen für Schäden durch die Verwendung von Informationen aus diesem Online-Angebot oder durch das Fehlen von Informationen. Dies gilt auch für Inhalte Dritter, die über dieses Angebot zugänglich sind.

EC 1: Actions induced by cranes

EC 1:

EC 1: Einwirkungen aus Kranen

Gerhard Sedlacek
Prof. Dr.-Ing.
RWTH Aachen
Civil Engineering
Aachen, Germany



Gerhard Sedlacek, born in 1939, is Professor for Steel Construction at the RWTH Aachen. He has been convener of the Project Team for the preparation of the chapter "Actions induced by cranes".

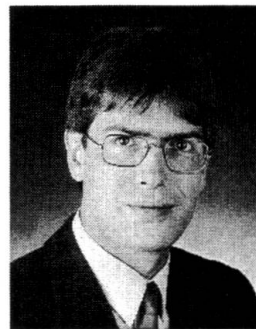

Dietmar Grotmann
Dipl.-Ing.
RWTH Aachen
Civil Engineering
Aachen, Germany

Dietmar Grotmann, born in 1961 is research engineer for steel construction at the RWTH Aachen.

SUMMARY

According to an agreement achieved in CEN, CEN/TC 250 prepares structural Eurocodes with design rules for buildings and civil engineering works whereas other CEN/TC's, that prepare rules for other products e.g. CEN/TC 147 develops a code for cranes, mainly develop rules for specific actions and methods of analysis for their fields and refer to the Eurocodes for resistances where possible.

Actions for the design of crane supporting structures which are caused by crane operations at the interface between crane structures and "buildings", i.e. the contact area between wheels and rails had to be given. In cooperation between CEN/TC 250/SC 1 and the relevant working group 2 of CEN/TC 147 specific crane actions for crane supporting structures were defined which comply both with the design philosophy in CEN/TC 147 and the safety assumptions and design procedures of the Eurocodes. This paper gives some basic principles and application rules on actions on crane supporting structures.

RÉSUMÉ

ZUSAMMENFASSUNG

Gemäß der in CEN erzielten Übereinstimmung ist das technische Komitee CEN/TC 250 beauftragt worden, Eurocodes für den Entwurf, die Berechnung und die Bemessung von Tragwerken des konstruktiven Ingenieurbaus zu entwickeln. Weitere technische Komitees von CEN erstellen für ihre Produkte spezielle Regeln (z.B. entwickelt CEN/TC 147 eine Norm für Krane). Sie entwickeln die Regeln für die speziellen Einwirkungen und Berechnungsmethoden und verweisen was die Beanspruchbarkeit angeht auf die Eurocodes, soweit dies möglich ist.

Für die Bemessung von Kranunterkonstruktionen wären die Einwirkungen festzulegen, die durch den Kranbetrieb an der Schnittstelle "Kran - Kranunterkonstruktion" die an der Kontaktfläche zwischen Rad und Schiene entstehen. In Zusammenarbeit mit der Arbeitsgruppe 2 von CEN/TC 147 wurde die Kranlast für die Kranunterkonstruktion festgelegt, die mit der Bemessungsphilosophie in CEN/TC 147 und den Sicherheitsanforderungen und Bemessungsabläufen der Eurocodes übereinstimmen. Dieser Aufsatz beschreibt einige wesentliche Regeln für die Einwirkungen auf Kranunterkonstruktionen



1. GENERAL AND SCOPE

Part 5 of Eurocode 1 deals with actions from cranes and machinery. It is therefore subdivided into 4 parts where Part 1 gives General rules, Part 2 deals with actions induced by cranes, Part 3 presents the Principles for determining actions from machinery and Part 4 gives practical wheel loads from transport vehicles such as lifters, helicopters, etc.

This paper presents the rules for actions from cranes, as these rules are rather detailed and operative. The rules have been developed by a Project team of CEN/TC250/SC1 in close cooperation with experts from CEN/TC147 and with the Project team of CEN/TC250/SC3 which in parallel developed rules for the resistance of steel crane supporting structures.

Actions induced by cranes comprise actions from hoists, crabs and cranes on runway beams. Accordingly the crane supporting structures are divided into 3 categories, see [figure 1](#):

- runway beams for hoist blocks
- runway beams for underslung overhead travelling cranes
- runway beams for bridge cranes

The standard gives principles and application rules for determining numerical values of crane actions defined by the forces exerted from the crane wheels to the rails.

The list of contents of part 5.2 can be taken from [figure 2](#).

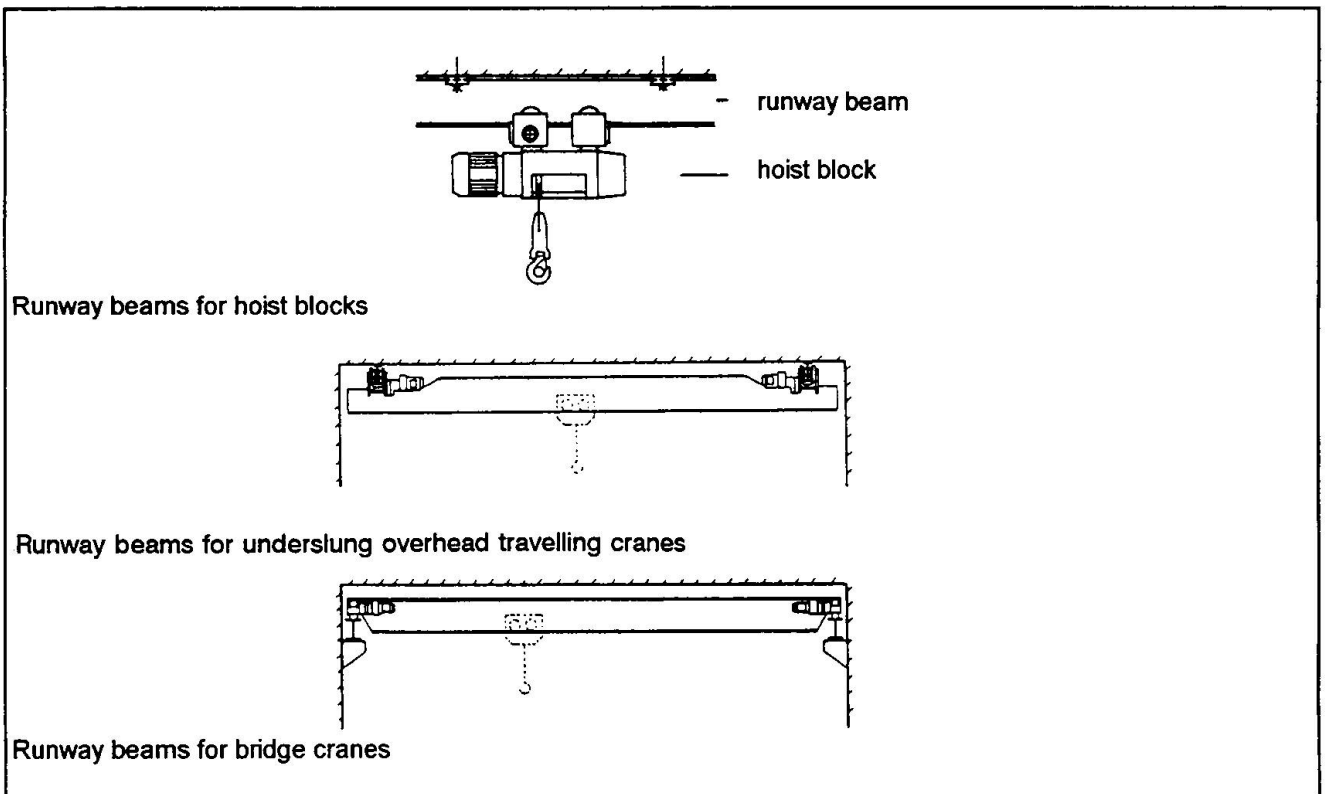

Figure 1: 3 categories of crane supporting structures

Part 5.2

Main text:	2.1	Scope
	2.2	Definitions
	2.3	Symbols
	2.4	Classifications of actions
	2.5	Design situations
	2.6	Representation of actions
	2.7	Load arrangements
	2.8	Vertical crane loads - characteristic values
	2.9	Horizontal crane loads - characteristic values
	2.10	Temperature effects
	2.11	Access walkways, stairs, platforms and guard rails
	2.12	Test loading
	2.13	Accidental loads
	2.14	Fatigue loads

Annex A: Basis of design - Supplementary clauses to ENV1991-1 for runway beams loaded by cranes

Figure 2: List of contents of part 5-2 "Actions induced by hoists, crabs and cranes on runway beams"

2. BACKGROUND OF THE MODELS AND CHARACTERISTIC VALUES

2.1 General

The actions induced by cranes are classified in variable and accidental actions. Variable actions result from variation in time and location, see [figure 3](#). They include:

- gravity loads including variable hoist loads
- inertial forces caused by acceleration/deceleration and by skewing
- dynamic effects

In addition actions are also specified for test loading, in case tests are performed with cranes on the supporting structures

Accidental situations lead to buffer forces, tilting forces etc.

Actions may be vertical and/or horizontal and are composed of a static and a dynamic component. The dynamic component in general is expressed in terms of a dynamic magnification factor to the static load:

$$Q_{k,i} = \varphi_i F_{k,i}$$

where $F_{k,i}$ is the static wheel load
 φ_i is the dynamic magnification factor
 $Q_{k,i}$ is the characteristic wheel load

[Figure 4](#) gives a survey on the type of the magnification factors to be considered for the static loads.

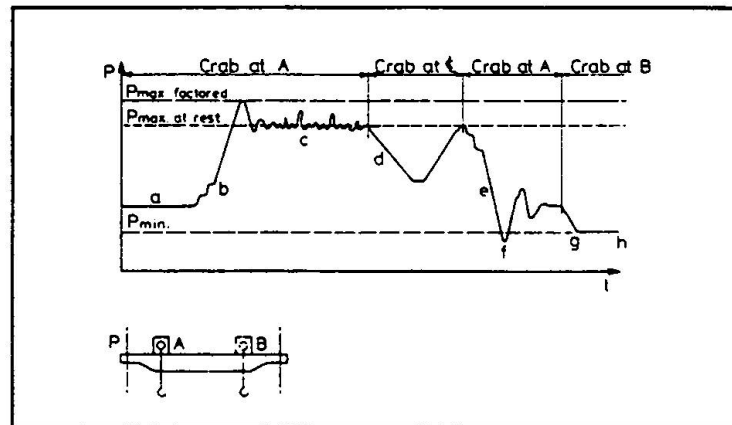

Figure 3: Example for the fluctuation of crane wheel reaction during a work cycle

Dynamic magnification factors	effects to be considered	to be applied to
Φ_1	- vibrational excitation of the crane structure due to lifting the hoist load off the ground	selfweight of the crane structure
Φ_2 or Φ_3	- dynamic effects of transferring the hoistload from the ground to the crane - dynamic effect of sudden release of the payload if for example grabs or magnets are used	hoistload
Φ_4	- dynamic effects induced when travelling on rail tracks or roadways	selfweight of the crane and hoistload
Φ_5	- effects caused by drive forces	horizontal forces
Φ_6	- when a test load is moved by the drives in the way the crane is used	test load
Φ_7	- considers the elastic effects of impact on buffers	buffer loads
Φ_8	- gust response factor	wind loads

Figure 4: Various dynamic magnification factors Φ_i

The simultaneity of the crane load components is taken into account by considering groups of loads defined in figure 5. Each of these groups of loads shall be considered as defining one characteristic crane action for the combination with non-crane loads.

2.2 Characteristic values

2.2.1 Basis

To determine the design values of the crane loads for ultimate limit state a reference period of 50 years and a reliability index $\beta = 3,80$ has been adopted. Based on these definitions the characteristic values Q_k were determined from the design values Q_d by

$$Q_k = \frac{Q_d}{\gamma_Q} \quad \text{where a single safety factor } \gamma_Q = 1,35 \text{ was used for all characteristic crane actions}$$

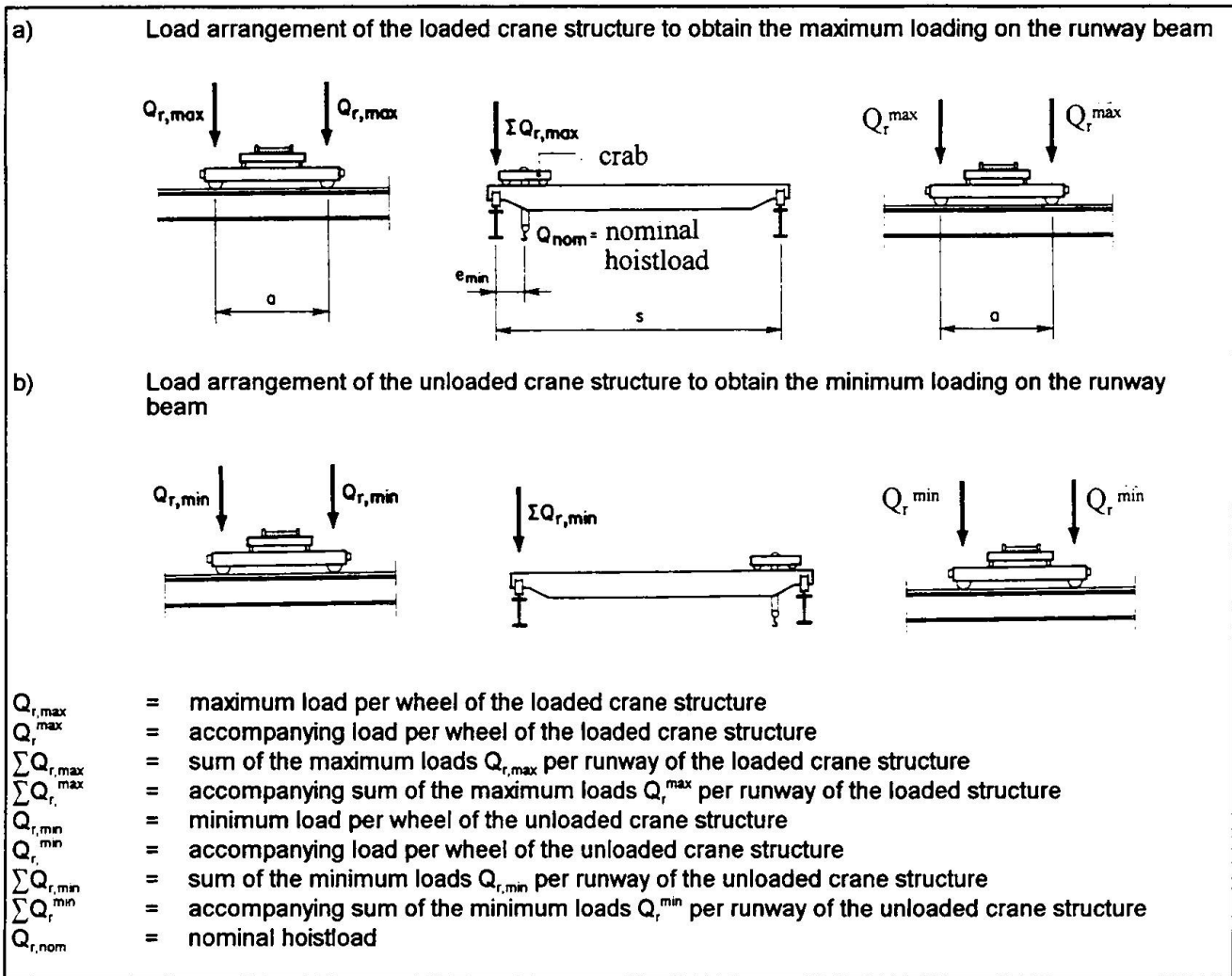

Figure 6 Load arrangements to obtain the relevant vertical actions to the runway girders

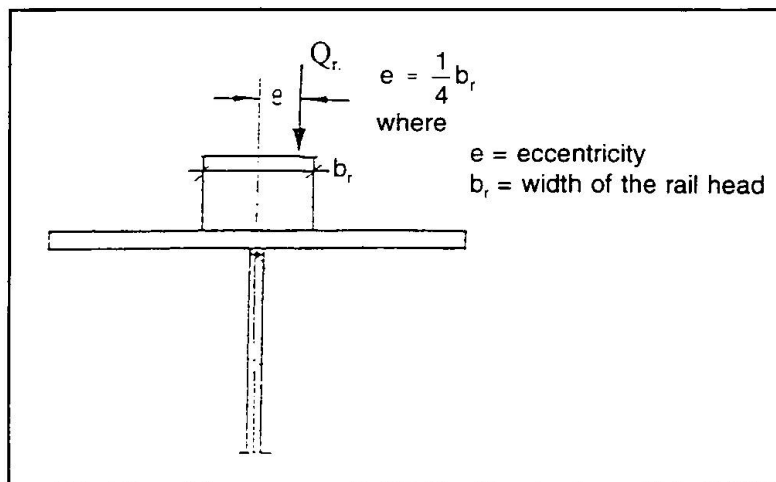

Figure 7 Eccentricity of the load introduction

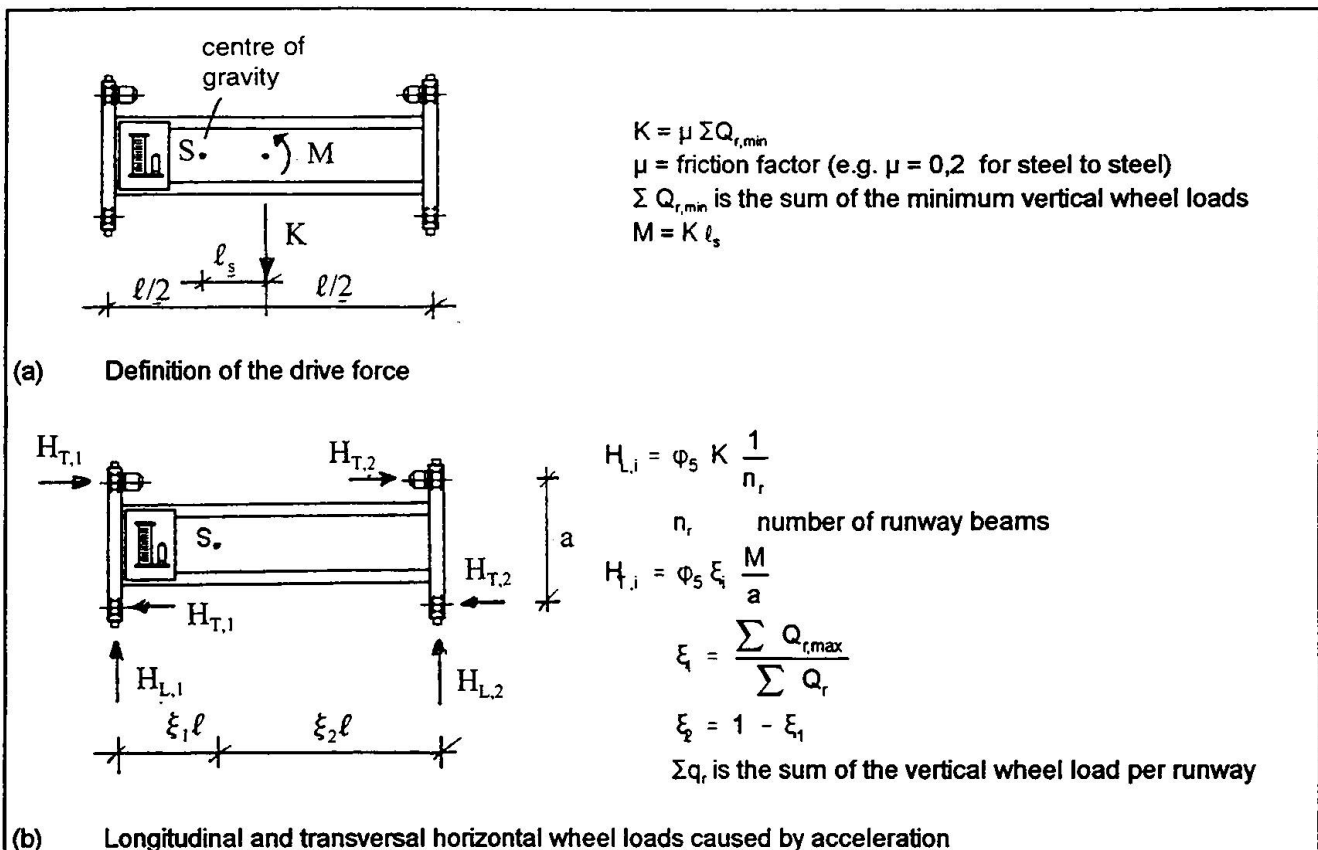

Figure 8 Horizontal wheel loads caused by acceleration

The horizontal crane loads caused by skewing are induced by guidance reactions which force the wheel to deviate from their free rolling natural travelling or traverse direction. These loads should be applied as longitudinal or transversal horizontal wheel loads H_{sL} and H_{sT} to the runway beams as shown in [figure 9](#).

The horizontal wheel loads caused by skewing may be obtained from:

$$H_{s,i} = f \lambda_{s,i} \sum Q_{r,max}$$

where f is a non-positive factor defined as

$$f = 0,3 (1 - \exp(-250 \alpha)) \leq 0,3$$

α = skewing angle, see [figure 9](#)

$\lambda_{s,i}$ is a force factor for $i = L$ (longitudinal) or $i = T$ (transversal) and the wheel j

The force factor $\lambda_{s,i}$ is depending on the combination of the wheel pairs and the distance h , determined according to [figure 10\(a\)](#) between the instantaneous slide pole and the guide means, see [figure 9](#). The value of the force factor $\lambda_{s,i}$ may be determined by the expressions given in [figure 10\(b\)](#).

The simultaneity of the horizontal loads caused by acceleration and skewing is defined in [figure 5](#) where the relevant groups of loads are given.

2.2.4 Test loading

After fabrication cranes are checked by test loads. If relevant the crane supporting structure shall be designed for these test loads to secure that no irreversible serviceability conditions occur.

When considering these test loads in the design of crane supporting structures the following two cases shall be distinguished:

case a: Dynamic test load:

The test load is moved by the drives in the way the crane will be used. The test load has to be at least

110% of the nominal hoist load.

$$\Phi_6 = 0,5 (1 + \Phi_2)$$

case b: Static test load:

The load is increased for testing by loading the crane without the use of the drives. The test load has to be at least 125% of the nominal hoist load.

$$\Phi_6 = 1,0$$

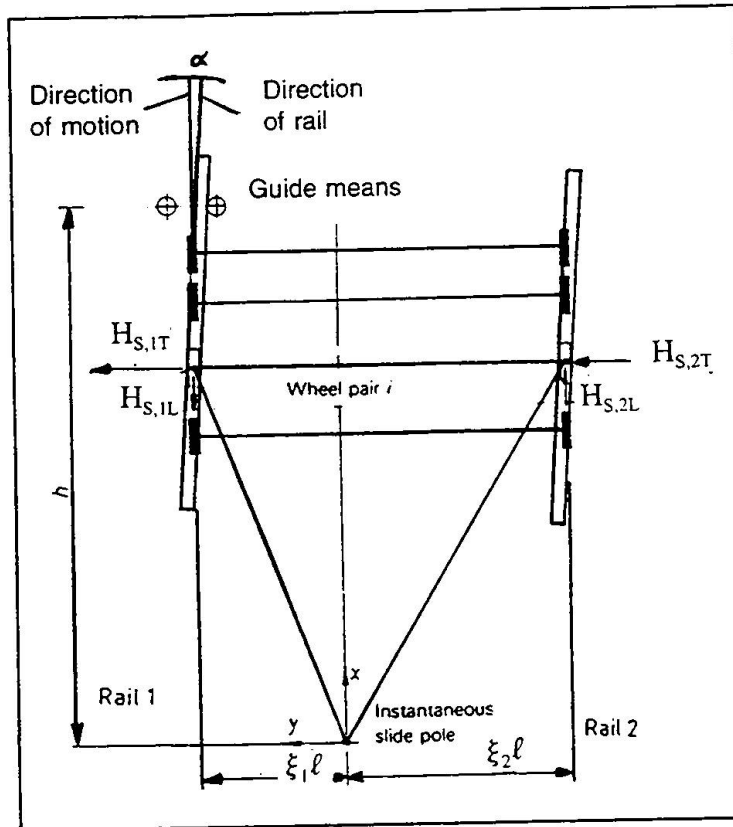

Figure 9 Definition of the horizontal forces caused by skewing

2.2.5 Accidental loads

Cranes may generate accidental actions due to collision with buffers or collision of lifting attachments with obstacles (tilting forces). These actions should be considered for the structural design where appropriate protection is not provided.

2.2.6 Fatigue loads

The fatigue loads shall be determined such, that the operational conditions of the distribution of hoist loads and the effects of the variation of crane positions to the fatigue details are duly considered for normal service condition .

In case detailed studies are not possible the fatigue loads may be expressed for practical reasons in terms of fatigue damage equivalent loads Q_e that may be taken as constant for all crane positions to determine fatigue load effects:

$$Q_e = \Phi_{fat} \wedge Q_{max}$$

where Q_{max} is the maximum value of the characteristic vertical wheel load



	Combination of wheel pairs		h
	coupled (c)	independent (i)	
Fixed/Fixed FF			$\frac{m\xi_1\xi_2\ell + \sum e_i^2}{\sum e_i}$
Fixed/Movable FM			$\frac{m\xi_1\ell + \sum e_i^2}{\sum e_i}$

h = distance between the instantaneous slide pole and the guide means
 m = number of pairs of coupled wheels (m = 0 for independent wheel pairs)
 ξ_1 = distance of the instantaneous slide pole from rail 1
 ξ_2 = distance of the instantaneous slide pole from rail 2
 ℓ = span of the appliance
 e_i = distance of the wheel pair i from the guide means

(a)

System	λ_s	λ_{s1L}	λ_{s1T}	λ_{s2L}	λ_{s2T}
cFF	$1 - \frac{\sum e_i}{nh}$	$\frac{\xi_1\xi_2\ell}{n} \frac{1}{h}$	$\frac{\xi_1}{n} \left(\frac{1 - e_i}{h} \right)$	$\frac{\xi_1\xi_2\ell}{n} \frac{1}{h}$	$\frac{\xi_1}{n} \left(\frac{1 - e_i}{h} \right)$
iFF		0	$\frac{\xi_1}{n} \left(\frac{1 - e_i}{h} \right)$	0	$\frac{\xi_1}{n} \left(\frac{1 - e_i}{h} \right)$
cFM	$\xi_1 \left(1 - \frac{\sum e_i}{nh} \right)$	$\frac{\xi_1\xi_2\ell}{n} \frac{1}{h}$	$\frac{\xi_1}{n} \left(\frac{1 - e_i}{h} \right)$	$\frac{\xi_1\xi_2\ell}{n} \frac{1}{h}$	0
iFM		0	$\frac{\xi_1}{n} \left(\frac{1 - e_i}{h} \right)$	0	0

n = number of wheel pairs
 ξ_1 = distance of the instantaneous slide pole from rail 1
 ξ_2 = distance of the instantaneous slide pole from rail 2
 ℓ = span of the appliance
 e_i = distance of the wheel pair i from the guide means
 h = instance between the instantaneous slide pole and guide means

(b)

Figure 10 Definition of $\lambda_{s,ij}$ - values

λ is the damage equivalent factor
 ϕ_{fat} is the damage equivalent dynamic impact factor

For determining the λ -value the use of cranes may be classified according to the load spectrum and the total number of load cycles as indicated in figure 11. The classification has been taken from the draft of the CEN standard prepared by CEN/TC147. Recommendations for the classifications of cranes are given in figure 12.

The values of the damage equivalent factor λ may be taken from figure 13 according to the crane classification chosen.

class of load spectrum						
class of total number of cycles ¹⁾	Q0	Q1	Q2	Q3	Q4	Q5
U0	S0	S0	S0	S0	S0	S0
U1	S0	S0	S0	S0	S0	S1
U2	S0	S0	S0	S0	S1	S2
U3	S0	S0	S0	S1	S2	S3
U4	S0	S0	S1	S2	S3	S4
U5	S0	S1	S2	S3	S4	S5
U6	S1	S2	S3	S4	S5	S6
U7	S2	S3	S4	S5	S6	S7
U8	S3	S4	S5	S6	S7	S8
U9	S4	S5	S6	S7	S8	S9

¹⁾ The classification is based on a total service life of 25 years

Figure 11 Classification of cranes according to TC 147

The damage equivalent dynamic impact factor ϕ_{fat} for normal conditions may be taken as:

$$\phi_{fat,1} = \frac{1 + \phi_1}{2}$$

$$\phi_{fat,2} = \frac{1 + \phi_2}{2}$$

2.2.7 Load combinations with other variable loads

For any combination of groups of loads induced by cranes together with actions specified in other parts of ENV 1991 any such combination shall be considered as one action.

When considering the groups of loads induced by cranes with other actions the following cases should be distinguished:

- case a: runways outside buildings; the runways are then fully exposed to climatic actions.
- case b: runways inside buildings where climatic actions are resisted by the buildings and structural elements of the buildings may also be loaded directly or indirectly by crane loads.

The combination factors ψ -factors for crane loads are as given in [figure 14](#).



item	Type of crane		classes
1	Hand-operated cranes		S0, S1
2	Erection cranes		S0, S1
3	Powerhouse cranes		S1, S2
4	Storage cranes	intermittend operation	S3, S4
5	Storage cranes, spreader bar cranes, scrap yard cranes	continuous operation	S5 to S9
6	Workshop cranes		S2 to S4
7	Bridge cranes, ram cranes	grab or magnet operation	S5 to S9
8	Casting cranes		S5 to S9
9	Soaking pit cranes		S7 to S9
10	Stripper cranes, charging cranes		S7 to S9
11	Forging cranes		S5 to S9
12	Transporter bridges, semi-portal cranes, portal cranes with trolley or slewing crane	Hook operation	S3 to S6
13	Transporter bridges, semi-portal cranes, portal cranes with trolley or slewing crane	grab or magnet operation	S5 to S9
14	Travelling belt bridge with fixed or sliding belt(s)		S2 to S4
15	Dockyard cranes, slipway cranes, fitting-out cranes	hook operation	S2 to S4
16	Wharf cranes, slewing, floating cranes, level luffing slewing	hook operation	S3 to S6
17	Wharf cranes, slewing, floating cranes, level luffing slewing	grab or magnet operation	S5 to S9
18	Heavy duty floating cranes, gantry cranes		S1, S2
19	Shipboard cargo cranes	hook operation	S2 to S4
20	Shipboard cargo cranes	grab or magnet operation	S3 to S6
21	Tower slewing cranes for the construction industry		S2
22	Erection cranes, derrick cranes	hook operation	S1, S2
23	Rail mounted slewing cranes	hook operation	S2 to S4
24	Rail mounted slewing cranes	grab or magnet operation	S3 to S6
25	Railway cranes authorized on trains		S3, S4
26	Truck cranes, mobile cranes	hook operation	S2 to S4
27	Truck cranes, mobile cranes	grab or magnet operation	S3 to S6
28	Heavy duty truck cranes, heavy duty mobile cranes		S0, S1

Figure 12 Recommended classification of cranes



λ factors	S0	S1	S2	S3	S4	S5	S6	S7	S8	S9
normal stresses	0,198	0,250	0,315	0,397	0,500	0,630	0,794	1,00	1,260	1,587
shear stresses	0,379	0,436	0,500	0,575	0,660	0,758	0,871	1,00	1,149	1,320

Figure 13 λ -values according to classification of cranes (service life 25 years)

Action	Symbol	ψ_0	ψ_1	ψ_2
group of load induced by cranes	Q_r	1,00	0,90	- ¹⁾
Wind Force	F_{wK} $F_w^{2)}$	0,6 1,0	0,5 0	0 0
Snow and ice	S	0,6	0,5	0
Temperature Effects	T_k	0,6	0,6	0,5

¹⁾ ratio between the permanent crane action and the total crane action

²⁾ Corresponding to maximum in service wind speed

Figure 14 ψ -factors for crane loads

REFERENCES

- [1] A.J. Beuker, H. Gulvanessian, G. Sedlacek, C. Urbano, G. Wagner, D. Grotmann: Members of CEN/TC250/SC 1/PT 13
- [2] ENV 1991-1: Eurocode 1: Basis of Design and Actions on Structures; Part 1: Basis of design, 1994
- [3] Crane Safety - Design General Proof calculation to prevent mechanical hazards by design; Part 1 to Part 3; Draft CEN/TC 147/ WG 2/ N 23 October 1995
- [4] Draft ENV 1993-6: Eurocode 3 - Part 6: Crane supporting structures
- [5] J. Oxfort: Zum Betriebsfestigkeitsnachweis für die Radlastwirkungen in Kranbahnträgern noch DIN 4132, Stahlbau 1/1983, pp 50-54
- [6] SIA 160: Einwirkungen auf Tragwerke, Ausgabe 1989

Leere Seite
Blank page
Page vide