

Effect of confinement on reinforced concrete columns subjected to eccentric loading

Autor(en): **Jaturapitakkul, Chai / Kiattikomol, Kraiwood / Chucheepsakul, Somchai**

Objekttyp: **Article**

Zeitschrift: **IABSE reports = Rapports AIPC = IVBH Berichte**

Band (Jahr): **81 (1999)**

PDF erstellt am: **21.07.2024**

Persistenter Link: <https://doi.org/10.5169/seals-61416>

Nutzungsbedingungen

Die ETH-Bibliothek ist Anbieterin der digitalisierten Zeitschriften. Sie besitzt keine Urheberrechte an den Inhalten der Zeitschriften. Die Rechte liegen in der Regel bei den Herausgebern.

Die auf der Plattform e-periodica veröffentlichten Dokumente stehen für nicht-kommerzielle Zwecke in Lehre und Forschung sowie für die private Nutzung frei zur Verfügung. Einzelne Dateien oder Ausdrucke aus diesem Angebot können zusammen mit diesen Nutzungsbedingungen und den korrekten Herkunftsbezeichnungen weitergegeben werden.

Das Veröffentlichen von Bildern in Print- und Online-Publikationen ist nur mit vorheriger Genehmigung der Rechteinhaber erlaubt. Die systematische Speicherung von Teilen des elektronischen Angebots auf anderen Servern bedarf ebenfalls des schriftlichen Einverständnisses der Rechteinhaber.

Haftungsausschluss

Alle Angaben erfolgen ohne Gewähr für Vollständigkeit oder Richtigkeit. Es wird keine Haftung übernommen für Schäden durch die Verwendung von Informationen aus diesem Online-Angebot oder durch das Fehlen von Informationen. Dies gilt auch für Inhalte Dritter, die über dieses Angebot zugänglich sind.



Effect of Confinement on Reinforced Concrete Columns Subjected to Eccentric Loading

Chai Jaturapitakkul
Assistant Professor
KMUT Thonburi
Bangkok, Thailand



Kraiwood Kiattikomol
Associate Professor
KMUT Thonburi
Bangkok, Thailand



Somchai Chucheeepsakul
Professor
KMUT Thonburi
Bangkok, Thailand



Anek Siripanichgorn
Assistant Professor
KMUT Thonburi
Bangkok, Thailand



Summary

In this experimental study, total number of 48 reinforced concrete columns with and without confinement under eccentric loading were conducted. For confined columns, transverse reinforcement was provided by tie with spacing of 5, 10, and 20 cm. Columns having the same confinement were tested under a compressive load with the eccentricity of 0, 3, 6, and 9 cm from the center-line of the cross section.

The results revealed that the columns with confinement can resist higher load than the one without confinement and the columns with smaller tie spacing give higher ultimate loads as well as larger lateral deflections than the ones with larger tie spacing. For columns under the same eccentricity, ties with smaller spacing have shown to be more effective in increasing the ultimate load of column than the ones with larger spacing. Finally, confinement also makes concrete column more ductile and has higher lateral deflection when subjected to the same loading.

1. Introduction

In designing reinforced concrete columns, the amount of main steel is calculated based on the loading and the strengths of steel and concrete. However, the amount of transverse reinforcement, either tie or spiral, was recommended by the requirement of code, for example, ACI 318 [1] specified that the spacing of tie shall not exceed 16 longitudinal bar diameters, 48 tie bar or the least dimension of column. When the concrete column was subjected to loading, it would be shortened in the longitudinal direction as well as expanded in the lateral direction. The use of transverse reinforcement reduces the hoop stress in the column, thus increases the capacity of column and makes it more ductile as compared to the one without confinement [2,3]. For high strength concrete column, the failure of column without confinement was suddenly occurred and dangerous. The use of transverse reinforcement as well as the higher amount of main bars made concrete column more ductile [4]. The rate of loading also affected

the behavior of concrete column. In case of plain concrete columns, the ones with very fast rate of loading failed suddenly like an explosion and took 35% higher load than the ones with medium rate of loading. The column with confinement was found to resist higher load and had more ductility for every rate of loading [5].

Many researchers [2-7] showed that the use of transverse reinforcement would increase the capacity and ductility of column. However, in all of the aforementioned works, the emphases were placed on columns subjected to concentric loading, a few works considered on one eccentricity. [3,6]. To cover the behavior of reinforced concrete columns under loading, the experimental program for columns with different tie spacings subjected to different eccentricities of loading were tested and studied.

2. Objective

The objective of this research was to investigate the behavior of short reinforced concrete columns with different tie spacings under eccentric and concentric loadings. The experimental and analytical results were compared and discussed.

3. Experimental Program

3.1 Reinforced Concrete Columns

Concrete columns with cross section of $20 \times 30 \text{ cm}^2$ and 120 cm in height with 6- $\varnothing 12$ mm main bars were cast. For confined columns, transverse confinement was provided by tie of $\varnothing 6$ mm with spacing of 5, 10, and 20 cm. After 28 days, the total 48 columns were tested with the varying eccentricities of 0, 3, 6, and 9 cm from the centerline of the cross section. For each eccentricity, 3 columns were tested. Fig. 1 shows the detail of tested columns

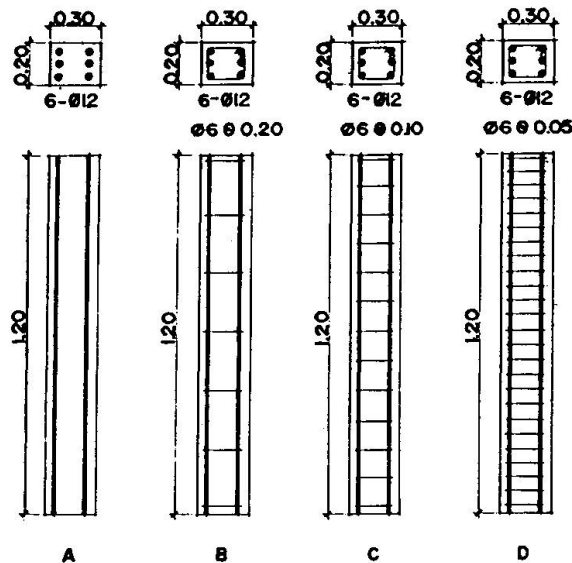

Fig. 1 Detail of main and tie bars of reinforced concrete columns

3.2 Testing of Concrete Columns

The procedure to test concrete columns can be described as follows:

-Place the column on a 200-ton universal testing machine. On the top and bottom faces of the column, a 1-inch thickness of steel plate was placed to transfer the applied load through the column as shown in Fig. 2.

-Dial gauge "a" was used to measure the shortening of column with gauge length of 100 cm. Dial gauges "b", "c", and "d" were placed at 10, 60, and 110 cm, respectively, from the top



of column in order to measure the lateral deflection due to eccentricity of loading. The schematic setting for column testing is shown in Fig. 3.

-Apply a uniform rate 4000 kg/minute of loading and record the shortening, lateral deflection of column for every incremental load of 5000 kg until the column was failed.

-D, C, B, and A were designated to those columns with ties spacing of 5, 10, 20 cm, and without tie, respectively. For columns A0, A3, A6, and A9, the suffix meant the eccentricity of loading and was 0, 3, 6, and 9 cm, respectively. This was also applied to columns with designation B, C, and D.

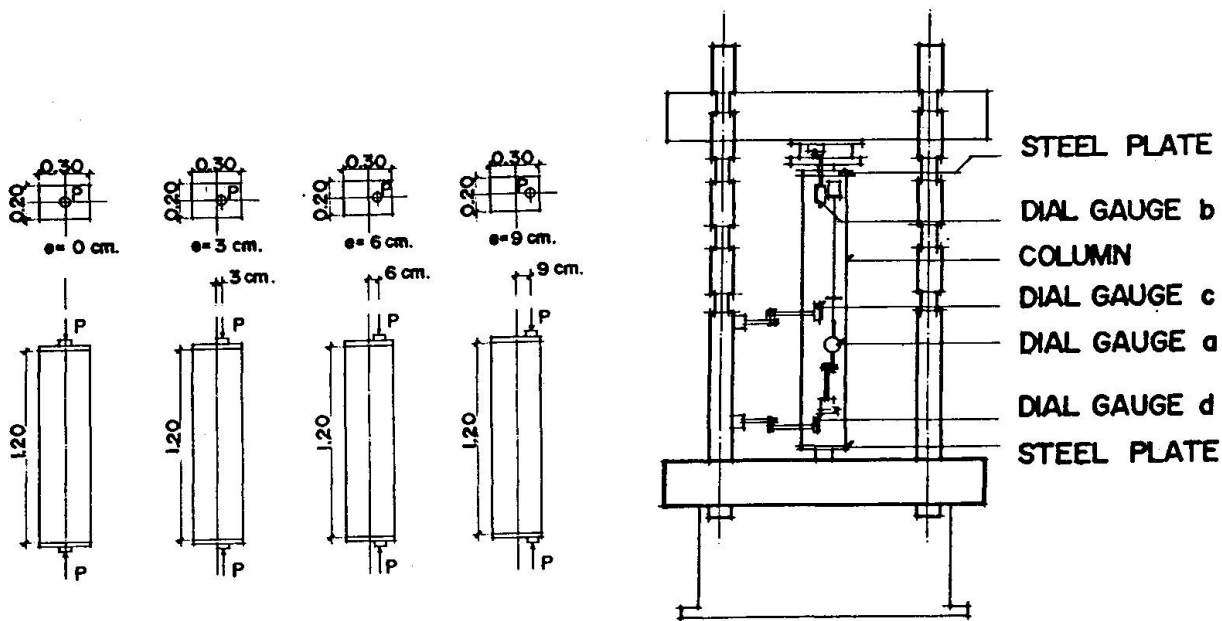

Fig. 2 Detail of column under eccentric loading Fig.3 Schematic setting for column testing

4. Results and Discussions

4.1 Properties of Concrete and Steel

The average compressive strength of standard cylinder at 28 days was 101.2 kg/cm^2 . The main and tie bars had yield strengths of 2884 and 2888 kg/cm^2 , and the elastic moduli were 2.177×10^6 and $2.132 \times 10^6 \text{ kg/cm}^2$, respectively.

4.2 Effect of Confinement on the Capacity of Columns

Table 1 shows the capacity of columns in resisting load. With confinement, the concrete columns resisted higher ultimate load than the ones without confinement. These results confirm to those obtained by other researchers [2,3,6,7]. With the same confinement, the columns tended to take less load as the eccentricity was increased. This is due to the failure of column caused by the combination of compression and bending. According to ACI code [1], the tested column should have tie spacing of 20 cm. It was found that the column with 20 cm tie spacing resisted 11.79% higher load than the one without tie, but 6.64 and 12.64% lower than the ones with tie spacing of 10 and 5 cm, respectively.

The use of confinement is more effective for column subjected to eccentric loading than the one subjected to concentric loading. With eccentricity of 3 cm, the ultimate loads of column were 80.75, 74.2, 64.52, and 55.3 tons for columns with ties of spacing 5, 10, 20 cm, and without tie, respectively or increasing of 46.02, 34.17, and 16.67% as compared to the ones without tie. At the same value of eccentricity, ties with smaller spacing have shown to be more effective in increasing the ultimate load of column than the ones with larger spacing.

Table 1 Strength of concrete columns under eccentric loading

Column No.	Tie Spacing (cm)	Eccen. (cm)	P _u (Exp.) (tons)	Load Increasing Compared to Column without Tie Bar (%)	Load Increasing Compared to Column with 20 cm Spacing (%)	Lateral Deflection at Mid-height (mm)
A0	-	0	64.78	-	-11.79	1.78
B0	20	0	73.44	13.36	-	2.97
C0	10	0	78.32	20.90	6.64	5.08
D0	5	0	82.73	27.69	12.64	4.72
A3	-	3	55.30	-	-14.29	1.95
B3	20	3	64.52	16.67	-	2.01
C3	10	3	74.20	34.17	15.00	2.08
D3	5	3	80.75	46.02	25.16	3.14
A6	-	6	47.70	-	-20.84	0.94
B6	20	6	60.27	26.33	-	1.52
C6	10	6	66.48	39.35	10.31	2.46
D6	5	6	70.76	48.31	17.40	3.57
A9	-	9	43.17	-	-24.28	1.01
B9	20	9	57.01	32.07	-	1.52
C9	10	9	62.54	44.86	9.70	2.21
D9	5	9	63.61	47.34	11.58	2.61

4.3 Ultimate Load of Columns from Experimental and Analytical Results

Following the procedures given in [8], the capacity of short reinforced concrete column can be calculated and the numerical example can be found in [9]. Table 2 shows the ultimate loads of columns from experimental and analytical results. It is seen that the capacities of columns without confinement from experiment are in good agreement with the analytical results. In case of column under eccentric loading, the ultimate load of column increases with the increase of confinement. For example, the column with eccentricity of 9 cm, and tie spacing of 20, 10, and 5 cm, the capacity of column is increased by 45.77, 59.91, and 62.64%, respectively, as compared to the one without confinement (by analytical result).

4.4 Relationship between Load and Strain of Columns

Relationships between load and strain of the tested columns are shown in Figs. 3 to 7. The strain of column in this experiment is caused by the combine action of compression and bending



moment due to eccentricity. At the same eccentricity, it was found that column with smaller spacing of tie gave higher ultimate load as well as higher ultimate strain before failure. This is due to the ties confining the core of concrete and making the core stronger than the one without or with lesser ties. At the same eccentricity and loading, column A (without tie) had higher strain than the other columns. It could be suggested that confinement increase the ductility as well as the capacity of column without increasing the amount of main bar.

4.5 Relationship between Load and Lateral Deflection of Columns

Relationships between load and lateral deflection of columns under different eccentricities of loading are shown in Figs. 8 to 11. At the same loading and eccentricity, the column with smaller spacing of tie had higher lateral deflection than the ones with larger spacing. In addition, the column with more confinement had higher deflection, and also obtained higher ultimate load at failure than the ones with less confinement. For example, in Fig. 11, at loading of 40 tons with eccentricity of 9 cm, column A9 (without tie bar) had lateral deflection of 0.54 mm while column D9 (tie spacing of 5 cm) had lateral deflection of 1.55 mm or three times higher. At the ultimate load, column A9 had load of 43.17 tons with the corresponding lateral deflection of 1.013 mm while column D9 yielded loading of 63.61 tons with the lateral deflection of 2.613 mm. Thus, the confinement can improve the ultimate load capacity as well as provide the ductility of concrete column, especially for column under eccentric loading.

Table 2 Ultimate load of concrete columns from experimental and analytical results

column No.	Tie Spacing (cm)	Eccentricity (cm)	P_u (Exp.) (tons)	P_u (Ana.) (tons)	P_u (Ana.) – P_u (Exp.)	
					(tons)	(%)
A0	-	0	64.78	70.60	-5.82	-8.24
A3	-	3	55.30	57.40	-2.10	-3.66
A6	-	6	47.70	47.13	+0.57	+1.21
A9	-	9	43.17	39.11	+4.06	+10.38
B0	20	0	73.43	70.60	+2.83	+4.01
B3	20	3	64.52	57.40	+7.12	+12.40
B6	20	6	60.27	47.13	+13.14	+27.88
B9	20	9	57.01	39.11	+17.90	+45.77
C0	10	0	78.32	70.60	+7.72	+10.93
C3	10	3	74.20	57.40	+16.80	+29.27
C6	10	6	66.48	47.13	+19.35	+41.06
C9	10	9	62.54	39.11	+23.43	+59.91
D0	5	0	82.73	70.60	+12.13	+17.18
D3	5	3	80.75	57.40	+23.35	+40.68
D6	5	6	70.76	47.13	+23.63	+50.14
D9	5	9	63.61	39.11	+24.50	+62.64

NO ECCENTRICITY

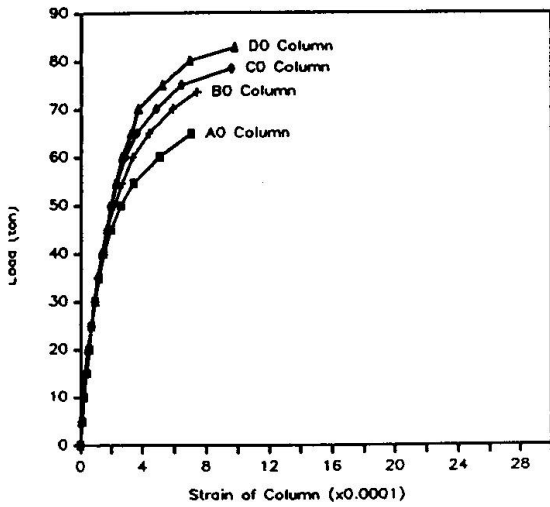

Fig. 4 Relationship between load and strain of columns under concentric loading

ECCENTRICITY = 3 cm

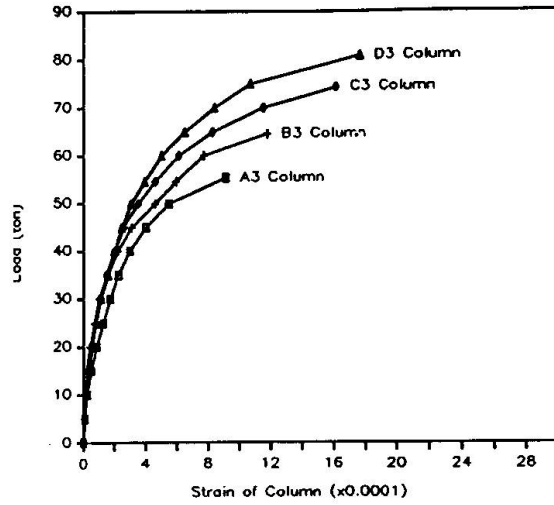

Fig. 5 Relationship between load and strain of columns under eccentricity of 3 cm

ECCENTRICITY = 6 cm

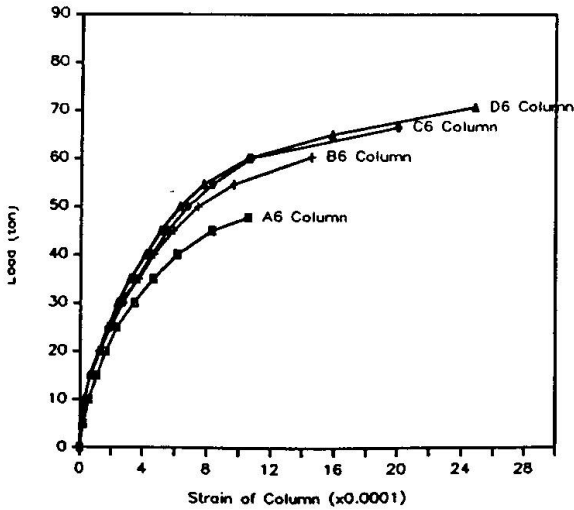

Fig. 6 Relationship between load and strain of columns under eccentricity of 6 cm

ECCENTRICITY = 9 cm

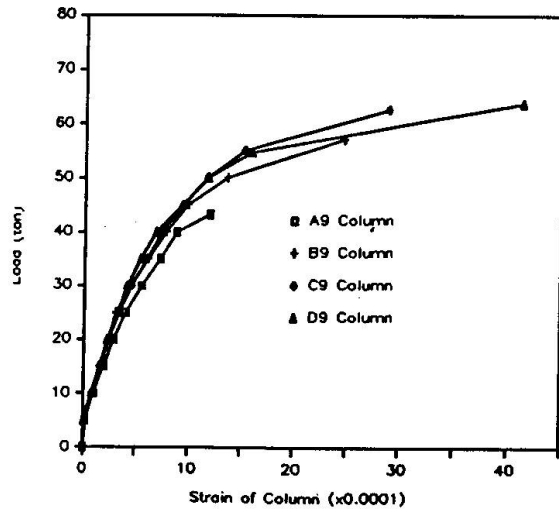

Fig. 7 Relationship between load and strain of columns under eccentricity of 9 cm

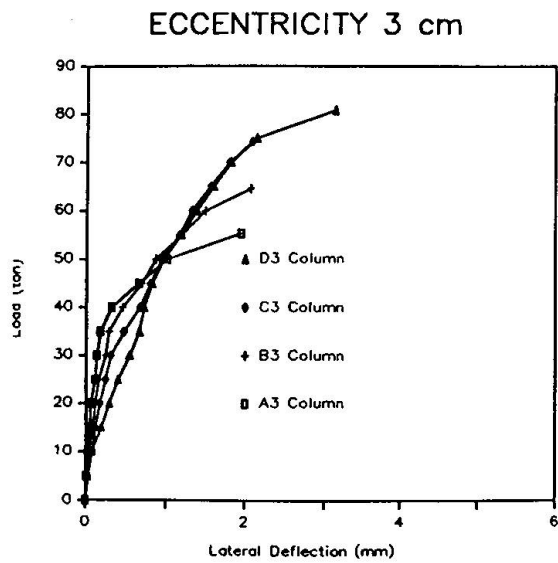

Fig. 8 Relationship between load and deflection of columns under concentric loading

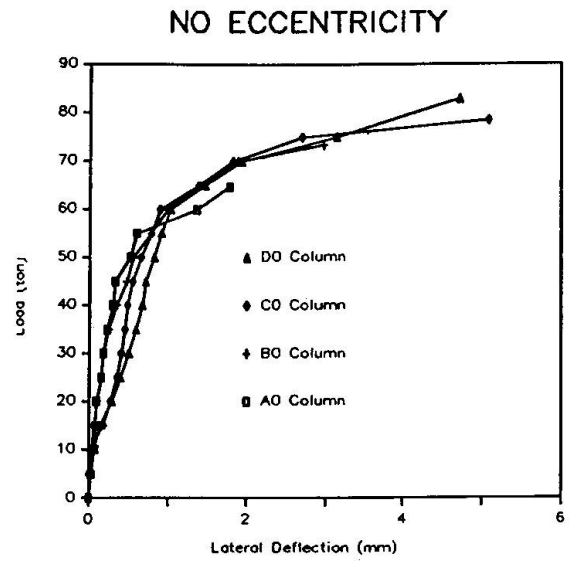

Fig.9 Relationship between load and deflection of columns under eccentricity of 3 cm

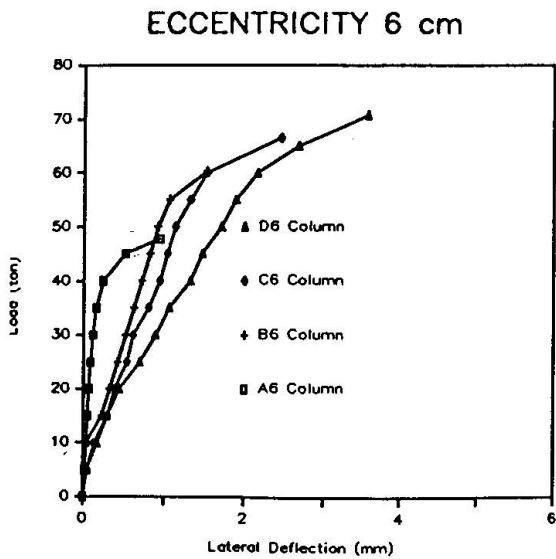

Fig. 10 Relationship between load and deflection of columns under eccentricity of 6 cm

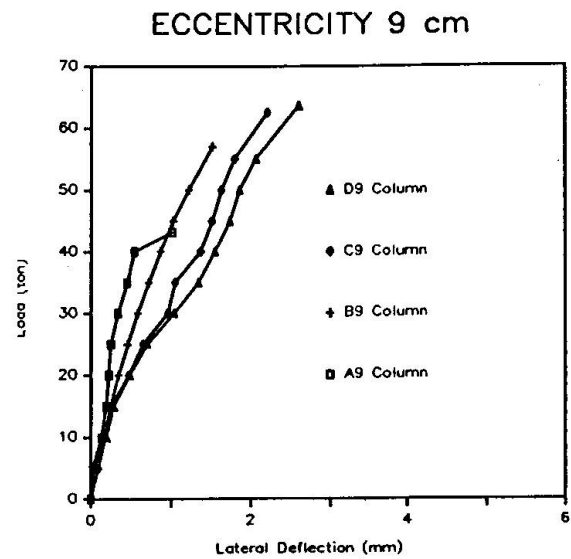

Fig.11 Relationship between load and deflection of columns under eccentricity of 9 cm

5. Conclusions

From this study, the conclusions can be drawn as follows:

1. Columns with smaller tie spacing resist higher ultimate loads than the ones with larger tie spacing.
2. Column under the same loading and eccentricity, closer tie spacing tended to give larger lateral deflection.
3. For columns under the same eccentricity, ties with smaller spacing have shown to be more effective in increasing the ultimate load of column than the ones with larger spacing.

6. Acknowledgement

The authors would like to thank the National Research Council of Thailand for providing financial support through the research grant to King Mongkut's University of Technology Thonburi. Many thanks are also extended to Mr. Boonchai C., Mr. Salaruk S., Mr. Surasak T., and Mr. Surasak N. for their efforts on preparing and testing the concrete columns.

7. References

1. ACI 318-89, 1992, "Building Code Requirements for Reinforced Concrete," *ACI Manual of Concrete Practice Part 3-1992*, American Concrete Institute.
2. Iyengar K. T. S. R., Desayi, P., and Reddy K.N., 1970, "Stress-Strain Characteristics of Concrete Confined in Steel Binders," *Mag. of Concr. Res.*, V. 22, No. 72, pp. 173-184.
3. Soliman, M. T. M. and Yu, C.W., 1967, "The Flexural Stress-Strain Relationship of Concrete Confined by Rectangular Transverse Reinforcement," *Mag. of Concr. Res.*, V. 19, No. 61, pp. 223-238.
4. Yong, Y. K., Nour, M. G., and Navy, E. G., 1988, "Behavior of Laterally Confined High-Strength Concrete Under Axial Loads," *J. of Str. Eng.*, V. 114, No. 2, pp. 332-351.
5. Dilger, W.H., Koch, R., and Kowalczyk, R., 1984, "Ductility of Plain and Confined Concrete Under Different Strain Rates," *J. of Amer. Concr. Inst.*, V. 81, No. 1, pp. 73-81.
6. Sargin, M., Ghosh, S.K., Handa, V.K., 1971, "Effects of Lateral Reinforcement Upon the Strength and Deformation Properties of Concrete," *Mag. of Concr. Res.*, V. 23, No. 75-76, pp. 99-110.
7. Gangadharam, D. and Reddy K.N., 1980, "Effect of Cover Upon the Stress-Strain Properties of Concrete Confined in Steel Binders," *Mag. of Concr. Res.*, V. 32, No. 112, pp. 147-155.
8. Nilson, A.H. and Winter, G. 1991, *Design of Concrete Structures*, 11th Edn., McGraw-Hill, pp. 284-295.
9. Jaturapitakkul, C., Kiattikomol, K., Chuchepkskul, S., and Siripanichgorn, A., 1997, "Effect of Confinement on Reinforced Concrete Columns", *Final Research Report to the National Research Council of Thailand*, King Mongkut's Institute of Technology Thonburi, 37 pp.