

**Zeitschrift:** Technische Mitteilungen / Schweizerische Post-, Telefon- und Telegrafienbetriebe = Bulletin technique / Entreprise des postes, téléphones et télégraphes suisses = Bollettino tecnico / Azienda delle poste, dei telefoni e dei telegrafi svizzeri

**Band:** 63 (1985)

**Heft:** 10

**Artikel:** Potential hazards to the eye by laser radiation in optical communication

**Autor:** Novak, Rostislav

**DOI:** <https://doi.org/10.5169/seals-875409>

### **Nutzungsbedingungen**

Die ETH-Bibliothek ist die Anbieterin der digitalisierten Zeitschriften. Sie besitzt keine Urheberrechte an den Zeitschriften und ist nicht verantwortlich für deren Inhalte. Die Rechte liegen in der Regel bei den Herausgebern beziehungsweise den externen Rechteinhabern. [Siehe Rechtliche Hinweise.](#)

### **Conditions d'utilisation**

L'ETH Library est le fournisseur des revues numérisées. Elle ne détient aucun droit d'auteur sur les revues et n'est pas responsable de leur contenu. En règle générale, les droits sont détenus par les éditeurs ou les détenteurs de droits externes. [Voir Informations légales.](#)

### **Terms of use**

The ETH Library is the provider of the digitised journals. It does not own any copyrights to the journals and is not responsible for their content. The rights usually lie with the publishers or the external rights holders. [See Legal notice.](#)

**Download PDF:** 06.10.2024

**ETH-Bibliothek Zürich, E-Periodica, <https://www.e-periodica.ch>**

# Potential hazards to the eye by laser radiation in optical communication

Rostislav NOVAK, Berne

## 1 Introduction

In modern optical communication systems, fibers represent the transmission medium, semiconductor laser diodes (LD) and light-emitting diodes (LED) are applied in optical transmitters, photo diodes in the receivers. Laser diodes and light-emitting diodes represent a special class of light sources, being connected with certain potential dangers to the human eye. Although the radiant power of these elements is far from being high by being ranging in the order of a few milliwatts, their power density ranges nevertheless – compared to their tiny radiation area of a few  $\mu\text{m}^2$  – to extremely high values. The high radiant density, combined with some unfavorable imaging optics, represents the basis for a possible eye injury.

The field of applied laser technology is still less than 20 years old. In its early stages, it was already recognized that the use of lasers is connected with possible hazards. Rapidly, investigations have been started to define the maximum permissible exposure values for the human eye. Limiting values were initially set up in a conference in Cincinnati, USA, in 1968. Since then, the values have been modified and extended on several occasions, adapting them to the newest state of research. Recently, all of these known facts have been summarized in the draft of norms of the Technical Commission TK-76 of the IEC, «Radiation Safety of Laser Products, Equipment Classification, Requirements and User's Guide» [1]. In Switzerland, the Federal Accident Insurance Administration (SUVA) has issued this document in German, together with the Swiss Electrotechnical Society (SEV). It has been extended by some supplementary recommendations for the protection of the eye in that issue [2, 3, 4].

On the whole, the preliminary activities in determining the danger limit as well as achieving a valid protection against laser radiation could therefore be regarded as terminated. In addition, the basic mechanisms of eye injury and their consequences are generally known as well. However, a still unsatisfactory fact is the lack of general awareness about all these aspects in the field of optical communication. This paper intends to close this gap. It will be demonstrated, under what circumstances hazards occur and what the means are to avoid them.

## 2 Characteristics of optical communication systems

The range of application of the aforementioned draft concerning eye safety shall be limited in the following to typical circumstances defined as follows:

– *Types of optical fibers:* Multimode graded index fibers (MUGI) and step index fibers (MUSI) with core diameter of  $50\ \mu\text{m}$  and a numerical aperture of  $NA = 0.2$ , monomode fibers (MOFA) with a mode diameter of

$8\ \mu\text{m} \dots 10\ \mu\text{m}$  and an effective numerical aperture of  $0.1 \dots 0.14$ .

- *Types of light sources:* Semiconductor lasers and LED's are considered as equivalent, both in CW- as well as in pulsed operation. He-Ne-lasers, often employed for some optical adjustment or fiber identification, are also taken into consideration.
- *Used wavelengths:* The present analysis ranges over the whole spectrum of optical communication, i.e.  $\lambda = 780\ \text{nm} \dots 1600\ \text{nm}$  with the exception of He-Ne-lasers ( $\lambda = 632.8\ \text{nm}$ ).
- *Ranges of radiation power:* Upper limits are 10 mW for CW or for average power and 2 W peak in pulsed operation.

## 3 The human eye

To illustrate the possibilities of eye injury, some facts about the eye itself shall be reiterated here. The shape of the eyeball is depicted in *Figure 1*. It is enclosed by a leather skin, converging into the cornea (1), at the frontal side. The cornea is part of an optical lens system, together with the eye lens (2). By the cornea, the anterior eye chamber (3), the lens and vitreous body (7), an image is generated at the retina (6) being the light sensitive part. It covers the side and rear parts of the inside of the eye and it contains the nervous conductors that allow the transmission of nervous stimuli to the brain. The adjustment of the focal length of the lens occurs by contraction, the so-called accommodation, by the aid of the ciliary muscle (5). The diameter of the beam of rays is limited by the iris, providing for a maximum opening diameter of 7 mm.

From the optical point of view, the eye resembles a photographic camera. In place of a photosensitive layer on which an image is formed, the retina provides for this function. A difference now occurs in the fact that the medium for the image is not air but a water-type fluid. Thus there are different media in the object and image

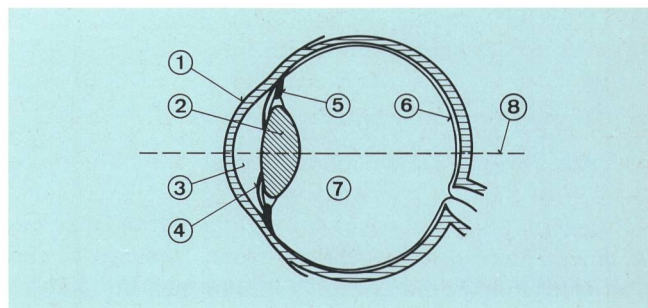

Fig. 1  
The human eye

- ① Cornea
- ② Eye lens
- ③ Anterior eye chamber
- ④ Iris

- ⑤ Ciliary muscle
- ⑥ Retina
- ⑦ Vitreous body
- ⑧ Optical axis

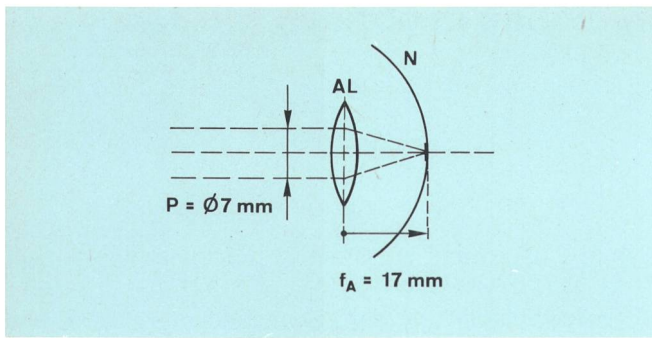

Fig. 2  
Optical equivalent of the human eye  
AL Eye lens  
N Retina  
P Aperture of the pupil  
 $f_A$  Focal length

ranges. The refractive index in the anterior eye chamber and in the vitreous body is identical to that of water ( $n = 1.336$ ). The eye lens, however, is not of homogeneous density. At its surface, a refractive index of 1.25 is observed whereas at the inside,  $n = 1.41$ . The deviation of the refractive index from that of its surroundings actually provides for its refractive power. From an optical standpoint, the eye can be represented as follows (Fig. 2): the optical equivalent of the human eye merely consists of a lens with a diameter of 17 mm and a maximum aperture width of 7 mm [5, 6].

What are now the transmission properties of the eye? In Figure 3, the transmission- and absorption-coefficients are represented, in function of the wavelength in the range of 600 nm...1600 nm. The curve T shows the portion of the radiation arriving at the retina. Curve A represents the portion of the initially available radiation that gets absorbed by the retina.

The range of wavelengths mentioned above can be divided into three zones (Fig. 3, line a). Wavelengths up to 780 nm represent the visible range (VIS). Wavelengths between 780 nm and 1400 nm belong to the so-called infrared range A (IR-A). Wavelengths above this zone belong to the infrared range B (IR-B) [7, 10]. In the range A representing the visible and infrared radiation, focusing occurs in the common way of the vision mechanism. Thus, a strong increase of radiant power density is possible by the available transparency and focussing of the eye. In the infrared range B, no radiant power reaches the retina, since absorption takes place already at the cornea. In addition, no perfect focussing is normally possible. In the wavelength region around 1400 nm...1600 nm, absorption takes place also in the eye lens and the eye chamber [8].

#### 4 Damage mechanisms in the eye

All cases of absorption mentioned so far have to be seen in a close relationship with possible eye injury. Damage of biological tissue through high radiant power or energy implies irreversible effects. Damage of this kind can be achieved primarily by thermal, but also by photochemical influences of the radiation. In any case, however, an absorption is involved.

Absorption occurs in the molecular or atomic structure of the tissue, generating a temperature increase. If the increase surpasses a certain limit, coagulation of cell

protein takes place. At an even higher temperature, cell burning effects may occur. Extremely short and energy-intensive pulses may cause immediate or even explosive evaporation of cell fluid.

The last case mentioned, however, can practically be excluded in the field of optical communication. Nevertheless, some type of tissue, such as skin, eye lens and especially the cornea may show irreversible reactions on a photochemical basis if it is exposed to laser radiation over longer time spans.

Seen from a medical standpoint, several types of injury can result. In the range of 780 nm...1400 nm, cataracts and cloudiness of the eye lens and/or thermal damage of the cornea can be expected. In the range of wavelengths above 1400 nm cataracts and/or burning effects on the cornea as well as glaring effects within the eye chamber fluid are probable (Fig. 3, line b).

In the range of optical communication, radiation generally becomes less dangerous with increasing wavelength. The reasons have already been explained at the end of section 3 [2, 9]. In the range of the third optical window (wavelengths of  $\lambda = 1500$  nm...1600 nm), any possibility of eye injury by optical communication equipment can practically be excluded.

#### 5 Maximum permissible exposure

The purpose of a safety limit is to define clearly, what is harmful under normal circumstances and what is not. In the case of eye irradiation hazards, a *corresponding limit* must be defined. For this purpose, a multitude of experiments involving monkeys and rabbits, as well as humans, have been performed. The maximum permissible exposure (MPE values) depends on many parameters as experiments showed: the wavelength  $\lambda$  of the laser, the time of exposure  $t$ , the impulse length  $T$ , the pulse rate  $N$ , as well as the properties of the tissue exposed. The irradiation values are generally referred to the plane of the cornea.

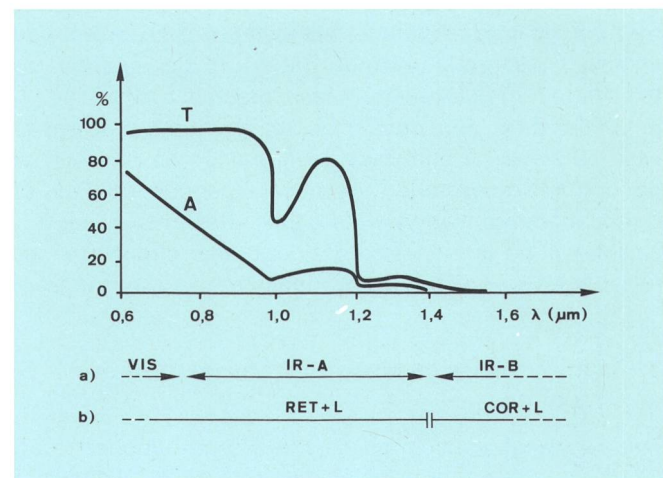

Fig. 3  
Transmission and absorption in the eye  
T Transmission  
A Absorption  
a) Subdivision of wavelength bands  
VIS Visible light  
IR-A Infrared, zone A  
IR-B Infrared, zone B  
b) Possible eye injury  
RET Retina  
L Lens  
COR Cornea

Maximum permissible exposure values are either given as *maximum permissible radiant exposure* [ $\text{J}\cdot\text{m}^{-2}$ ], for pulsed operation, or *maximum permissible irradiance* [ $\text{W}\cdot\text{m}^{-2}$ ], for continuous operation, depending on the case applying. The radiant exposure  $H$  is generally defined as the ratio of the differential radiant energy  $dQ$  [J] versus the differential surface area  $dA$  [ $\text{m}^2$ ], on which the energy emerges.

$$H = \frac{dQ}{dA} \quad [\text{J}\cdot\text{m}^{-2}] \quad (1)$$

Similarly, the irradiance  $E$  is the ratio of the differential radiant power  $dP$  [W] versus the differential surface area  $dA$  [ $\text{m}^2$ ].

$$E = \frac{dP}{dA} \quad [\text{W}\cdot\text{m}^{-2}] \quad (2)$$

Table I summarizes the MPE values which are significant for the range of optical communication [1, 2].

## 6 Typical cases of potential hazards to the eye

An optical transmission system consists of many components: an optical transmitter, fibers and cables, connectors, splicings and finally, a receiver with optically passive components. An equipment of this type is normally fully *encapsulated* and may therefore be classified as *Class I laser*, according to [1, 2]. No laser radiation can therefore leak out, the equipment is completely harmless.

The development, installation, maintenance and repair after failure involves, however, *open* equipment with the possibility of emerging radiation. In practice, the following typical cases may occur:

- Observation of the frontal end of a fiber, e.g. in a connector, with the bare eye

- Observation of light emitted from a LD or a LED with the bare eye
- Observation of the frontal end of a fiber with viewing aids (microscope, magnifying glass)
- Observation of the light of a He-Ne-laser directly in the beam axis, for example in the process of fiber identification
- Observation of He-Ne-laser light emerging from a fiber

In the following, it is investigated under what circumstances the irradiation of the eye must be regarded as hazardous.

## 6.1 Observation of the frontal end of a fiber with the bare eye

The emergence of a light beam from a fiber end is bound to be guided by the laws of refraction and diffraction. In the case described, the *far field distribution* applies. A rotationally symmetrical cone can thus be assumed (Fig. 4). The power or the energy within a differential spatial angular element,  $dP/d\Omega$ , respectively  $dQ/d\Omega$ , is thus expressed by

$$\frac{dP}{d\Omega} = \frac{P}{\int_0^{\Omega_c} f(\Theta) d\Omega} f(\Theta); \quad f(\Theta = 0) = 1 \quad (3)$$

respectively by

$$\frac{dQ}{d\Omega} = \frac{Q}{\int_0^{\Omega_c} f(\Theta) d\Omega} f(\Theta); \quad f(\Theta = 0) = 1 \quad (4)$$

where  $P$  is the total radiant power,  $Q$  is the total radiant energy,  $\Theta$  is the angle to the fiber axis and  $f(\theta)$  represents the normalized radiation characteristic of the fiber [11, 12].

Table I. Maximum permissible exposure values  $H$  [ $\text{J}\cdot\text{m}^{-2}$ ] resp.  $E$  [ $\text{W}\cdot\text{m}^{-2}$ ] for direct exposure of eye cornea by laser radiation. Excerpt from [1]

Exposure time $t$ (s)	Wavelength $\lambda$ [nm]								Limiting aperture $\varnothing$
	$10^{-9}$	$10^{-9}$ to $10^{-7}$	$10^{-7}$ to $18 \times 10^{-6}$	$18 \times 10^{-6}$ to $50 \times 10^{-6}$	$50 \times 10^{-6}$ to 10	10 to $10^3$	$10^3$ to $10^4$	$10^4$ to $3 \times 10^4$	
550...700	$5 \times 10^6 \text{ Wm}^{-2}$	$5 \times 10^{-3} \text{ Jm}^{-2}$	$t < T_2$ $18 t^{0.75} \text{ Jm}^{-2}$		$t > T_2$ $C_3 \times 10^2 \text{ Jm}^{-2}$		$C_3 10^{-2} \text{ Wm}^{-2}$	7 mm	
700...1050	$5 C_4 \times 10^6 \text{ Wm}^{-2}$	$5 C_4 \times 10^{-3} \text{ Jm}^{-2}$	$18 C_4 t^{0.75} \text{ Jm}^{-2}$				$3,2 C_4 \text{ Wm}^{-2}$	7 mm	
1050...1400	$5 \times 10^7 \text{ Wm}^{-2}$	$5 \times 10^{-2} \text{ Jm}^{-2}$			$90 t^{0.75} \text{ Jm}^{-2}$		$16 \text{ Wm}^{-2}$	7 mm	
1040...10 <sup>6</sup>	$10^{11} \text{ Wm}^{-2}$	$100 \text{ Jm}^{-2}$	$5600 t^{0.25} \text{ Jm}^{-2}$		$1000 \text{ Wm}^{-2}$			1 mm	

Remarks:

a)  $C_3 = 10^{0,015 (\lambda - 500)}$

b)  $C_4 = 10^{(\lambda - 700)/550}$

c)  $T_2 = 10 \cdot 10^{0,02 (\lambda - 550)}$

d) These values for maximum permissible exposure are valid for  $t < 10 \mu\text{s}$  and  $N \leq 1$  Hz.

At  $N > 1$  Hz, the values must be reduced by a correction factor  $C_5$ .

For  $1 \text{ Hz} < N \leq 278$ :  $C_5 = 1/\sqrt{N}$

For  $N > 278$ :  $C_5 = 1/\sqrt{278} = 0,06$

In other cases, consult [1] for calculation procedure.

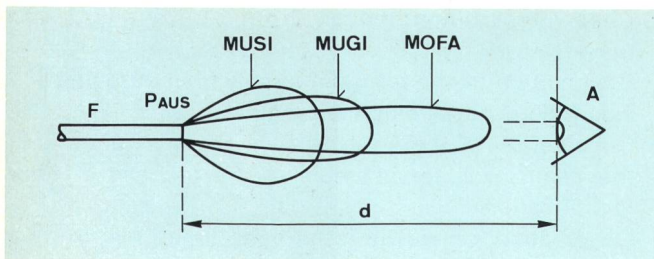

Fig. 4  
Light exit from fiber

MUSI	Multimode step index fiber	$P_{AUS}$	Radiant power
MUGI	Multimode graded index fiber	A	Eye
MOFA	Monomode fiber	d	Distance
F	Fiber		

The irradiance  $dP/dA$  is obviously constant in a small spatial angle and has its maximum on the fiber axis. Its value in a distance  $d$  from the fiber end is thus

$$\frac{dP}{dA} = \frac{1}{d^2} \cdot \frac{dP}{d\Omega} \Big|_{\Theta=0} \quad (5)$$

By solving these equations, the minimum optical hazard distance  $d_{CRIT}$  can be determined from a given value of the maximum permissible exposure.

$$d_{CRIT} = \frac{1}{NA} \sqrt{\frac{P}{\pi \cdot \text{MPE value}}} \cdot \begin{cases} \sqrt{\frac{\alpha+2}{\alpha}} & \text{for MUSI, MUGI} \\ D(v) & \text{for MOFA} \end{cases} \quad (6)$$

NA thus represents the numerical aperture of the fiber and  $\alpha$  the exponent of the index profile. The coefficient  $D(v)$  defines the ratio of the optical hazard distances of the mono- versus multimode step index fibers with given NA.  $D(v)$  can assume values between 2 and 4 [13].

Similar relationships are valid for  $dQ/dA$ . In the formulas (5) and (6),  $P(W)$  has to be replaced with  $Q(J)$  in this case.

In the following, actual values of the optical hazard distance between fiber and eye will be indicated for the first ( $\lambda = 850$  nm) and the second ( $\lambda = 1300$  nm) optical window for various fibers. The cases of continuous wave as well as pulsed operation with various radiant power levels, respectively energies, are investigated.

## 611 Continuous wave operation (CW)

The results are summarized in Table II. The values of the maximum permissible exposure for the case of continuous operation are taken from Table I in the form of irradiance [ $Wm^{-2}$ ], assuming an exposure time of  $t \geq 1000$  sec.

## 612 Pulsed operation

As an example, the optical fibre reflectometers *Tektro-nix* OF 150 ( $\lambda = 850$  nm), OF 152 ( $\lambda = 1300$  nm) for multimode fibers, and OF 151 ( $\lambda = 1300$  nm) for monomode fibers are investigated. Such equipments are, among others, utilized within the Swiss PTT and they can be regarded as representative for other but similar equipments [14]. Typical values for radiant energies, pulse lengths and pulse rates for the calculations are taken from equipment data sheets. The MPE values in the form of the radiant exposure [ $Jm^{-2}$ ] are taken again from Table I. The results are presented in Table III.

## 62 Observation of light emitted from a LD or a LED with the bare eye

Concerning the radiation emanating from a laser diode or a light emitting diode, the *farfield distribution* applies as well. The power density of a LD is basically higher than that of a LED. Everything that will be stated here about the safety aspects of a LD is thus applicable to LED's as well.

In defining the energy, respectively the intensity-distribution of a LD, equ. (6) is applied. However, one has to recognize that the radiation pattern becomes elliptical as a result of the differing numerical apertures in the two orthogonal planes of radiation. Figure 5 shows the existing relationships. Thus, equ. (6) can be modified for the minimum optical hazard distance as follows:

$$d_{CRIT} = \sqrt{\frac{1}{NA(\alpha) \cdot NA(\beta)}} \cdot \sqrt{\frac{P}{\pi \cdot \text{MPE value}}} \quad (7)$$

by

$$NA(\alpha) = \sin \frac{\alpha}{2} \text{ et } NA(\beta) = \sin \frac{\beta}{2} \quad (8)$$

Table II. Minimum optical hazard distance  $d_{CRIT}$  in millimetre between eye and fiber end. Continuous operation

$\lambda$ [nm]	MPE [ $W \cdot m^{-2}$ ]	P (CW) [mW]	$d_{crit}$ [mm] for fiber			Remark
			MUSI	MUGI	MOFA	
850	6,4	1	35	50		* (hypothetical value)
		2	50	71		
		10*	112	158		
1300	16	1	22	32	70	* (hypothetical value)
		2	31	45	100	
		10*	71	100	220	

\* Practical values are presently about 1 mW

MPE Maximum permissible exposure  
MUSI Multimode step index fiber

MUGI Multimode graded index fiber  
MOFA Monomode fiber

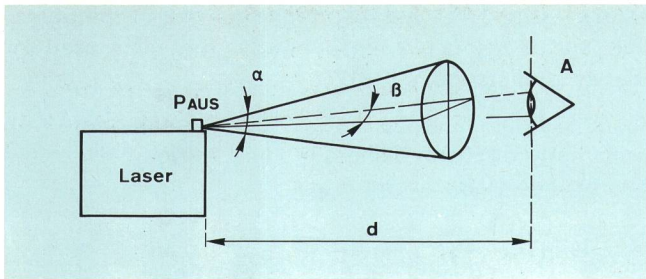

Fig. 5  
Light exit from laser diode

$P_{AUS}$  Radiant power  
 $\alpha$  Radiant angle, vertical plane  
 $\beta$  Radiant angle, horizontal plane  
 A Eye  
 d Distance

are the numerical apertures of the radiant angles  $\alpha$  and  $\beta$ . The angles obviously vary, depending on the type of diode. Table IV shows values for the minimum optical hazard distances involving typical laser diodes.

### 63 Observation of the frontal end of a fiber with the optical imaging instruments

Often, the properties of a fiber end have to be inspected, for example, in an optical connector or a fiber being prepared for splicing. For this purpose, microscopes and magnifying glasses are used. A magnified, focussed image thus appears at the retina of the eye. In the case, however, that the fiber is connected to an optical source, which might occur quite probably in an actual operational case, the radiation emerging from the fiber would reach the eye. Under certain circumstances,

the total available energy may actually be distributed over the actual image formed on the retina. In this case, a near field distribution and image is formed.

To define the maximum permissible exposure, Table I applies. The values given in this table, however, relate to the plane of the cornea. From these, the accessible emission limit in the eye (AELE) is determined by considering a maximum opening area of the pupil of  $40 \text{ mm}^2$ .

$$AELE = \frac{MPE}{t} \cdot 40 \cdot 10^{-6} [\text{W}, \text{J} \cdot \text{m}^{-2}, \text{s}]$$

$$= MPE \cdot 40 \cdot 10^{-6} [\text{W}, \text{W} \cdot \text{m}^{-2}] \quad (9)$$

where  $t(\text{s})$  is the exposure time.

Table V. Accessible emission limit in the eye. Value at the retina

$\lambda$ [nm]	t [s]	AELE [ $\mu\text{W}$ ]
850	10	800
	100	450
	1000	250
1300	10	2000
	100	1100
	1000	600

Table V indicates example values for exposure times of 10, 100 and 1000 sec, at wavelengths of 850 nm and 1300 nm. As a general rule, these values are related to a

Table III. Minimum optical hazard distance  $d_{CRIT}$  in millimetre, between eye and fiber end. Pulsed operation

$\lambda$ [nm]	MPE [ $\text{J} \cdot \text{m}^{-2}$ ]	P (puls) [mWpp]	$d_{CRIT}$ [mm] for fiber				Remark	
			MUSI	MUGI	MOFA			
					NA = 0,14	NA = 0,1		
850	$6 \cdot 10^{-4}$	760 2000*	24 38	33 54			OF 150 *(hypothetical value)	
1300	$3 \cdot 10^{-3}$	30 500*	10 42	14 59			OF 152 *(hypothetical value)	
1300	$3 \cdot 10^{-3}$	8 100*			29 100	40 140		OF 151 *(hypothetical value)

Table IV. Minimum optical hazard distance  $d_{CRIT}$  in millimetre between eye and laser diode. Valid for average power or continuous wave operation

Typical LD	$\alpha$	$\beta$	$\lambda$ [nm]	MPE [ $\text{W} \cdot \text{m}^{-2}$ ]	$d_{crit}$ [mm] for power P [W]		
					1 mW	2 mW	10 mW
Single heterostructure	$18^\circ$	$10^\circ$	850	6,4	31	42	98
Double heterostructure	$50^\circ$	$11^\circ$	850	6,4	19	27	60
Stripe CW	$50^\circ$	$6^\circ$	850	6,4	26	37	82
From fiber pigtail NA = 0,2	$\sim 23^\circ$	$\sim 23^\circ$	850	6,4	36	52	114
From fiber pigtail NA = 0,2	$\sim 23^\circ$	$\sim 23^\circ$	1300	16	22	32	70

NA = Numerical aperture

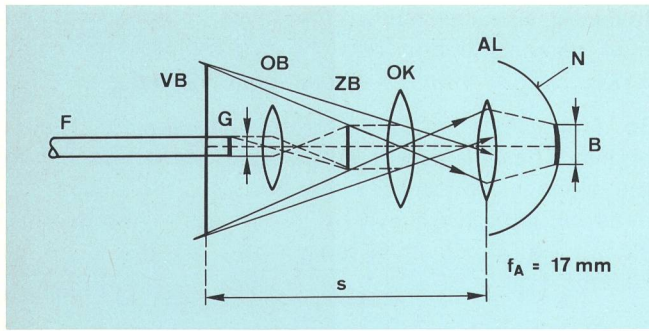

Fig. 6  
Principle of imaging by a microscope

VB	Virtual image	F	Fiber
OB	Objective	G	Object
ZB	Intermediate image	B	Image
OK	Ocular	f <sub>A</sub>	Focal length
AL	Eye lens	s	Visual distance
N	Retina		

theoretical point image on the retina. In reality, the image is expected to be somewhat enlarged over a certain finite area, due to ever-present movements of the eye as well as some thermally induced fluctuations in the eye fluid. Within this finite area, the radiation, however, may be distributed arbitrarily. If larger ranges are illuminated, a similar irradiation value per range is allowed. The size of such ranges is defined by the limiting angular subtense  $\alpha_{\min}$ , being dependent again on the wavelength of the light as well as the time of exposure. For the range of wavelengths used in optical communication and for exposure times that are larger than 10 sec, this angular subtense is  $\alpha_{\min} = 0.0244$  rad [1, 7], yielding a diameter  $D_N$  of the exposed area on the retina of  $414 \mu\text{m}$ . If a larger area is now illuminated, the portion of light to be considered in respect to eye safety has to be reduced. That reduced portion of the radiant power  $P_{\text{RED}}$  depends on the effective power reaches the eye  $P_{\text{ERF}}$  as follows:

$$P_{\text{RED}} = P_{\text{ERF}} \left( \frac{414}{D_N} \right)^2 \text{ f\"ur } D_N \geq 414 \text{ (!) [W, } \mu\text{m]} \quad (10)$$

### 631 Use of a microscope

Figure 6 depicts the process of imaging in a microscope (not by scale). The object G shall be the end of the fiber F. The eye lens AL and the retina N represent the optical equivalent of the eye with the reduced focal length  $f_A = 17$  mm. The objective OB and the ocular OK represent the optical parts of the microscope. The objective forms a magnified intermediate image ZB. In conjunction with the eye lens, the ocular magnifies this image, forming the virtual image VB in a visual distance s. This virtual image finally is transformed to a real image B on the retina, where

$$\frac{B}{f_A} = \frac{VB}{s} \quad (11)$$

The size of the image then becomes

$$B = f_A \frac{VB}{s} = f_A \frac{G \cdot A_{\text{OB}} \cdot A_{\text{OK}}}{s} \quad (12)$$

where  $A_{\text{OB}}$  and  $A_{\text{OK}}$  are the magnifications of the objective, and of the ocular, respectively. The value used for the visual distance is  $s = 250$  mm.

As an example, the size of the image of a fiber core with a diameter of  $50 \mu\text{m}$  using a magnification of 100 of the microscope yields at the retina

$$B = 17 \frac{50 \cdot 10 \cdot 10}{250} = 340 [\mu\text{m}] \quad (13)$$

In determining the portion of the energy emanating from the fiber that reaches the eye, the following criteria are applicable:

- In a *binocular microscope*, the radiant power to each eye is halved.
- The optical losses of the microscope are negligible.
- The numerical aperture of the fiber is assumed to be  $NA_{\text{max}} = 0.2$ , those of the eye (eff. focal length of  $f = 17$  mm and opening of the pupil of  $\varnothing 7$  mm) as  $NA = 0.2$ , as well. For microscope objectives with  $NA < 0.2$ , the portion of the radiant power  $P_{\text{ERF}}$  entering the eye is derived as follows:

$$P_{\text{ERF}} = P_{\text{OUT}} \cdot \left( \frac{NA_{\text{OBJECTIV}}}{0,2} \right)^2 \quad (14)$$

where  $P_{\text{OUT}}$  is the total radiant power emanating from the fiber.

The maximum permissible exposure times  $t_B$  that result under these circumstances are thus summarized in Table VI. The optical inspection equipment for the connectors, type Diamond OID-003 as presently utilized at the PTT, is included in the analysis (see last line).

### 632 Use of a magnifying glass

Figure 7 represents the imaging process of a magnifying glass (not by scale). The object G be the end of the fiber F. The eye lens AL together with the retina N, is again the optical equivalent of the eye. The lens L generates an enlarged virtual image VB within the visual distance. On the retina, a real image B finally appears.

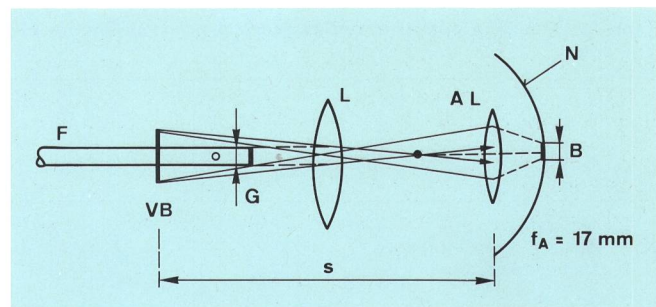

Fig. 7  
Principle of imaging by a magnifying glass

F	Fiber	N	Retina
VB	Virtual image	B	Image
G	Object	f <sub>A</sub>	Focal length
L	Lens	s	Visual distance
AL	Eye lens		

Table VI. Maximum permissible exposure time  $t_B$ . Use of microscope

Microscope BI Binocular MO Monocular			Multimode fiber 50/125						
Type	Objective	Ocular	$D_N$ [ $\mu\text{m}$ ]	$P_{\text{out}} = 1 \text{ mW}$			$P_{\text{out}} = 10 \text{ mW}$		
				$P_{\text{red}}$ [ $\mu\text{W}$ ]	$t_B$ [s] at		$P_{\text{red}}$ [ $\mu\text{W}$ ]	$t_B$ [s] at	
					$\lambda = 850 \text{ nm}$	$\lambda = 1300 \text{ nm}$		$\lambda = 850 \text{ nm}$	$\lambda = 1300 \text{ nm}$
BI	4x /0,1	10x	136	125	<1000	<1000	1250	G	G
BI	10x /0,25	10x	340	500	<100	<1000	5000	G	G
BI	20x /0,45	10x	680	200	<1000	<1000	2000	G	G
BI	40x /0,65	10x	1360	50	<1000	<1000	500	<100	<1000
MO OID-	10x /0,08 003	10x	340	160	<1000	<1000	1600	G	G

Microscope BI Binocular MO Monocular			Monomode fiber 8/125						
Type	Objective	Ocular	$D_N$ [ $\mu\text{m}$ ]	$P_{\text{out}} = 1 \text{ mW}$			$P_{\text{out}} = 10 \text{ mW}$		
				$P_{\text{red}}$ [ $\mu\text{W}$ ]	$t_B$ [s] at		$P_{\text{red}}$ [ $\mu\text{W}$ ]	$t_B$ [s] at	
					$\lambda = 850 \text{ nm}$	$\lambda = 1300 \text{ nm}$		$\lambda = 850 \text{ nm}$	$\lambda = 1300 \text{ nm}$
BI	4x /0,1	10x	22	125	<1000	<1000	1250	G	G
BI	10x /0,25	10x	54	500	<100	<1000	5000	G	G
BI	20x /0,45	10x	108	500	<100	<1000	5000	G	G
BI	40x /0,65	10x	216	500	<100	<1000	5000	G	G
MO OID-	10x /0,08 003	10x	54	160	<1000	<1000	1600	G	G

<100 Limited use (<100 s)  
 G Hazardous (<10 s)  
 $P_{\text{red}}$  Reduced power

The relationship of equ. (12) to define the size of the image B has to be modified slightly for a magnifying glass

$$B = f_A \frac{VB}{s} = f_A \frac{G \cdot A_L}{s} \quad (15)$$

where  $A_L$  is its magnification.

$$B = 17 \frac{50 \cdot A_L}{250} = 3,4 A_L [\mu\text{m}] \quad (16)$$

The magnification factors of magnifying glasses are around 2,5 for single lens systems (Fig. 8) and around 15 for double lens systems (Fig. 9). This means, that the diameter of an image on the retina can never be larger than 414  $\mu\text{m}$ , corresponding to the limiting angular subtense of 0.0244 rad mentioned in section 63. For the judgement of possible injury of the eye, solely the portion of radiant power  $P_{\text{ERF}}$  passing through lens and pupil ( $\varnothing 7 \text{ mm}$ ) is of concern.

$$P_{\text{ERF}} = P_{\text{AUS}} \cdot \left(\frac{7}{D}\right)^2 \quad [\text{W, mm}] \quad (17)$$

where  $P_{\text{OUT}}$  is the total radiant power out of the fiber and D is the maximum diameter of the beam applicable immediately in front of the eye.

This diameter for single lens systems is determined as follows:

$$D_1 \approx 2 \cdot a \cdot \text{NA} \quad (18)$$

and

$$D_2 \approx 4 \cdot a \cdot \text{NA} \quad (19)$$

for double lens systems, where a is the working distance between magnifying glass and fiber and NA is the numerical aperture of the fiber.

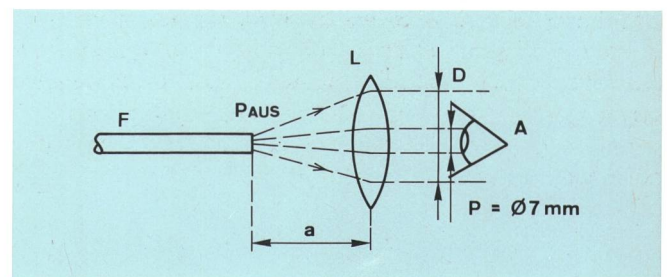
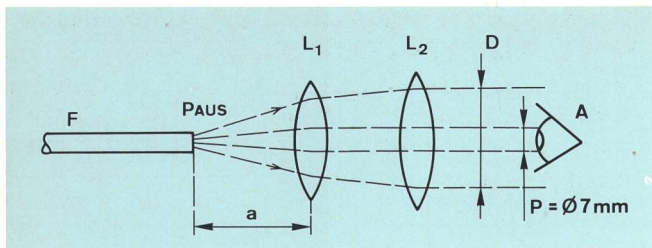

Fig. 8 Single lens magnifying glass – light exit from fiber

F Fiber A Eye  
 $P_{\text{AUS}}$  Radiant power P Pupil  
 L Lens a Working distance  
 D Maximum beam diameter





**Fig. 9**  
**Double lens-magnifying glass – light exit from fiber**  
 F Fiber A Eye  
 P<sub>AUS</sub> Radiant power a Working distance  
 L<sub>1</sub>, L<sub>2</sub> Lenses P Aperture of pupil  
 D Beam diameter in plane of eye

Table VII summarizes the maximum permissible exposure times by employing various types of typical magnifying glasses.

#### 64 Observation of the light of a He-Ne-laser directly in the beam axis

In various manipulations involving optical communication equipment, a He-Ne-laser is utilized. It radiates the visible red light ( $\lambda = 632.8 \text{ nm}$ ) in a narrow beam and is used for aligning optical components or for identifying the fibers of a fiber transmission cable. The radiation characteristics being valid for such a case are again the *far field type*. Since the visible light is sensed by the eye, a corresponding eye lid shutting reflex takes place after about 0.25 sec. The following investigations therefore concern a time duration of this range. Also a continuous exposure during  $10^4 \text{ sec}$  is considered.

The beam diameter  $w$  of a He-Ne-laser diverges at larger distances, leading to a corresponding decrease of the irradiance  $E$ . The corresponding relationships are illustrated in Figure 10. Assuming a gaussian intensity distribution, the irradiance at a distance  $d$  becomes

$$E = \frac{4P}{\pi (w + d\rho)^2} \quad (20)$$

where  $P \text{ [W]}$  is the total radiant power and  $\rho$  the divergence [15]. The minimum optical hazard distance  $d_{\text{CRIT}}$  thus corresponds to the maximum permissible exposure.

$$d_{\text{CRIT}} = \frac{\sqrt{\frac{4P}{\pi \cdot \text{MPE}} - w}}{\rho} \quad (21)$$

The MPE values for  $t = 0.25 \text{ sec}$  and  $t = 10^4 \text{ sec}$  are taken from Table I. The values for the optical hazard distance  $d_{\text{CRIT}}$  calculated for various types of lasers utilized by the PTT are summarized in Table VIII.

**Table VIII. Minimum optical hazard distance  $d_{\text{CRIT}}$  in metre between eye and exit of the He-Ne-laser. Direct look into beam**

Laser-Type	P [mW]	a [mm]	$\rho$ [mrad]	$d_{\text{CRIT}}$ [m] for	
				t = 0,25 s MPE = 25,4 W · m <sup>-2</sup>	t = 10 <sup>4</sup> s MPE = 0,18 W · m <sup>-2</sup>
155	0,5	0,9	1,0	4,1	59
142	2,0	0,5	1,7	5,6	70
132/133	3,5	1,0	5,0	2,4	31
120	> 5,0	0,8	1,1	13,7	170
124	> 15,5	1,1	1,0	26	325

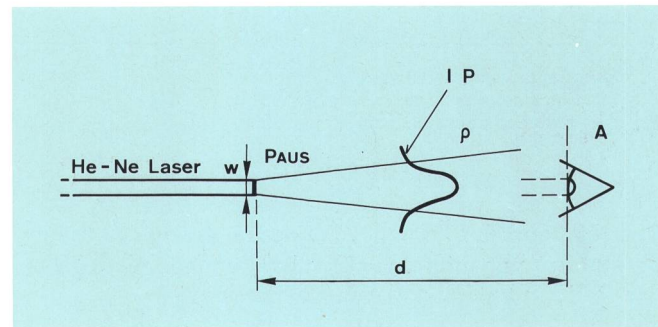

**Fig. 10**  
**Light exit from a He-Ne-laser**  
 w Diameter of exit beam  $\rho$  Beam divergence  
 P<sub>AUS</sub> Radiant power A Eye  
 IP Intensity profile d Distance

**Table VII. Maximum permissible exposure time  $t_b$ . Use of magnifying glass**

Magnifying glass				P <sub>out</sub> = 1 mW		P <sub>out</sub> = 10 mW		
Type	a [mm]	D [mm]	P <sub>erf</sub> [ $\mu\text{W}$ ]	$t_b$ [s] at		P <sub>erf</sub> [ $\mu\text{W}$ ]	$t_b$ [s] at	
				$\lambda = 850 \text{ nm}$	$\lambda = 1300 \text{ nm}$		$\lambda = 850 \text{ nm}$	$\lambda = 1300 \text{ nm}$
16 × Cylindrical	9	7,2	1000	G	< 100	10 000	G	G
15 × Cylindrical	12	9,6	500	< 100	< 1000	5 000	G	G
2 × Cylindrical	44	17,6	160	< 1000	< 1000	1 600	G	G
2,5 Flat	88	35,2	40	< 1000	< 1000	400	< 100	< 1000

< 100 Limited use (< 100 s)  
 G Hazardous (< 10 s)  
 P<sub>erf</sub> Power entering the eye  
 P<sub>out</sub> Total output

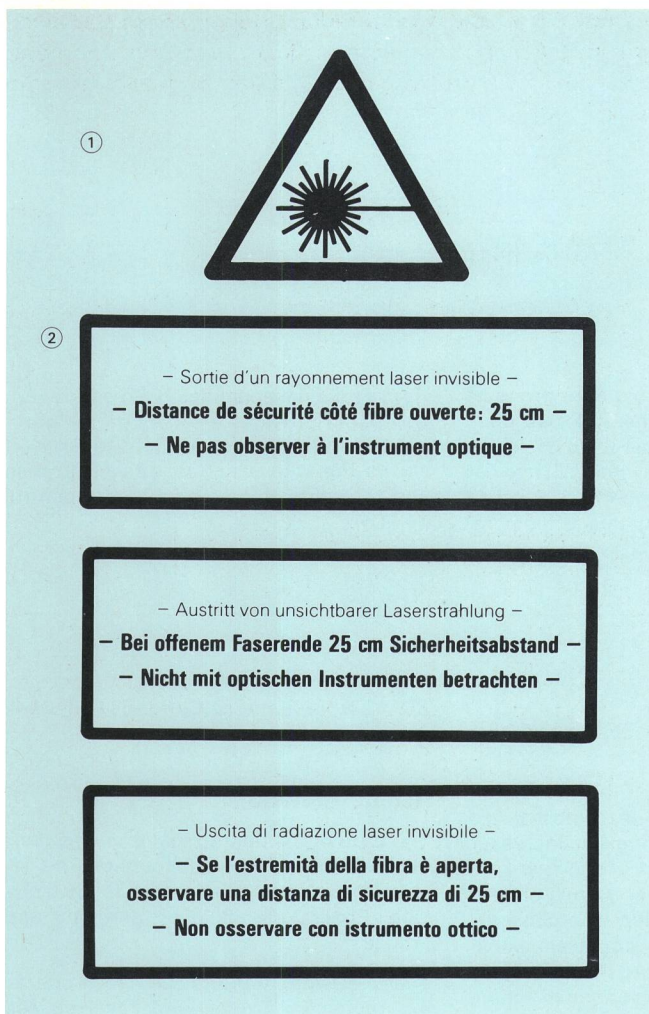

Fig. 11  
Warning labels  
① Hazard label

② Explanatory label

## 65 Observation of He-Ne-laser light emerging from a fiber

For identification of a fiber in a cable, the laser light is coupled into the fiber by means of a microscope objective. At the end of the fiber, the radiant power  $P_{\text{fiber}}$  is, however, quite low, as test results prove (Tab. IX). No danger is therefore to expect.

Table IX. Radiant power at fiber end. He-Ne-laser light. Coupling by microscope objective

$P_{\text{laser}}$ [mW]	Fiber	Objective	$P_{\text{fiber}}$ [ $\mu\text{W}$ ]
2	Siecor 50/125/0,2 2 m	40 $\times$ 0,65	36
		20 $\times$ 0,4	38
		10 $\times$ 0,25	12

## 7 Safety regulations at the PTT

An analysis of Tables II to IX indicates the circumstances under which a possible hazard may occur to the human eye by use of LD's or LED's in optical communication. In collaboration with various departments of the PTT and the Federal Accident Insurance Agency (SUVA), an official PTT instruction has been issued [16],

indicating the various possible hazards. In addition, some guidelines are contained in this document concerning safety aspects during exploitation of optical transmission equipment. The protection measures mentioned are mandatory for all divisions of the Swiss PTT. They shall be summarized as follows:

- In normal operation, an optical transmission equipment is fully *encapsulated* and therefore belongs to the Class 1 laser. Such equipment is therefore harmless.
- In all manipulations on *open* optical equipment, a minimum *optical hazard distance of 25 cm* is to be maintained.
- The observation of a fiber end with viewing aids, such as microscopes or magnifying glasses can present a *danger*. In such cases the person involved in measurements must make absolutely sure that the optical transmitter is turned off. A double check involving a suitable optical test apparatus is mandatory.
- All equipment portions representing danger for the human eye under certain circumstances are to be marked by *hazard*- as well as *supplementary explanatory labels* (Fig. 11).
- For identification, the coating of a fiber cable is to be colored in *orange* or must be marked by at least an orange longitudinal stripe.
- Direct light radiation from a He-Ne-laser must be regarded as *dangerous* in any case.
- According to the present state of the art of research, *no* labour-related medical measures are required (e.g. no periodic medical eye examinations).

A remark concerning fiber cable rupture in the field: To this time, in various countries, an automatic switch-off of the laser supply is required in such a mishap. It has been shown that the minimum optical hazard distance between a fiber end and the human eye is under normal conditions 25 cm. In the case of an arbitrarily broken fiber, the radiant angle is larger than in a plane rupture, a reduced radiant exposure thus is to be expected. The PTT as well as the SUVA therefore do not require an automatic switch-off. A similar conclusion was reached in other countries, among them in the Federal Republic of Germany [9].

## 8 Final remarks

With this paper referring to the safety regulations and directives of the Swiss PTT, an attempt has been made to determine and to describe the possible hazards present in all activities involving optical communication equipment. The analysis of the problem bases on the assumption that the MPE values given in [1] are in accordance with the latest state of research. It is generally assumed nevertheless that the conditions for a potential hazard are rather less critical in a real environment, since the actual limits of eye injury are generally even higher. In addition, the human eye is not always able to focus perfectly on an object being at the minimum optical hazard distance of 25 cm or less. Certain potential hazards to the eye in using any kind of viewing aids can in no way be neglected, however. But as indicated, instructions with respect to the required steps to be taken are now readily available.